

CJ700B-A/CJ700B-2/CJ700B-6使用说明书



中国长江

挎子就是长江

Frame Number and Engine Number

Please record the motorcycle numbers as indicated below and store the spare key in a safe place. Only the existing key can be used for creating a duplicate key. In case both keys are lost, it is needed to replace the whole set of lock sets.

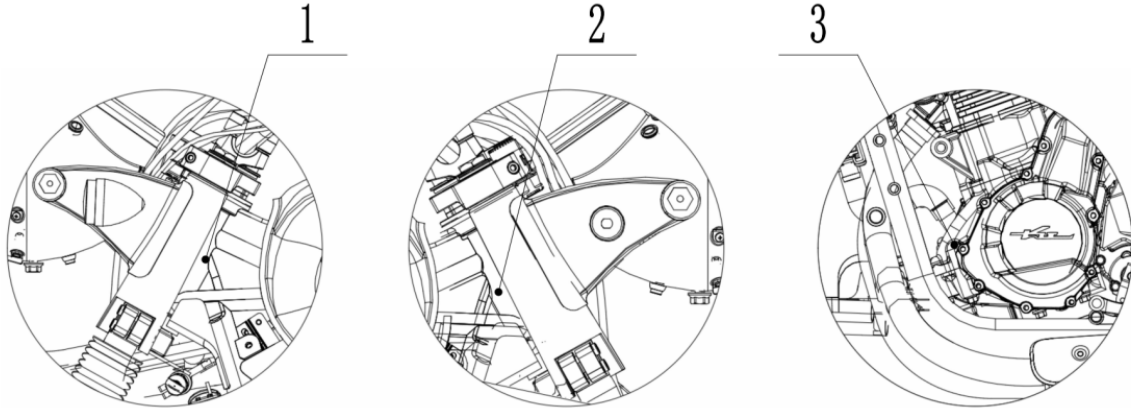

① car nameplate: _____

② Frame No.: _____

③ Engine No.: _____

Parameters

Performance

Item	Parameter	Item	Parameter
Maximum power (kW)/corresponding rotation speed (r/min)	55/8500	Maximum torque (N·m)/corresponding rotation speed (r/min)	68/6500

Size

Item	Parameter	Item	Parameter
Length (mm)× Width (mm)× Height (mm)	2460×1655×1070	Wheelbase (mm)	1500
Seat height (mm)	840	Ground clearance (mm)	170
Complete car curb weight (KG)	365		

Engine

Item	Parameter	Item	Parameter
Type	Double-cylinder, four-stroke, water-cooling,	Displacement (mL)	693

	paralleling upright		
Cylinder diameter (mm) × stroke (mm)	83×64	Compression ratio	11.6:1
Starting system	Electrical starting	Ignition order	From left to right, 1-2
Fuel mixing system	Electronic fuel injection system	Ignition system	Electronically-controlled inductance discharge ignition
Ignition advance Angle (before top dead center compression position)	10BTDC@1450r/min	Electron ignition advance angle	33BTDC@6000r/min
Spark plug	CR8EI	Lubrication system	Pressure splash lubrication (semi-dry oil sump)
Oil type	ELF Company 10W-40/SJ Level JASO MA2 certified oil	Oil volume (L)	2.6
Coolant volume (mL)	900	Side tank volume (L)	400

Transmission

Item	Parameter	Item	Parameter
Gearshift method	Sixth gear international standard gear	Clutch type	Wet multi-pad, manual clutch
Driving system	Chain drive	Primary reduction ratio	2.095
Gear ratio of first gear	2	Gear ratio of second gear	1.435
Gear ratio of third gear	1.154	Gear ratio of fourth gear	1
Gear ratio of fifth gear	1.667	Gear ratio of sixth gear	3.6

Chassis

Item	Parameter	Item	Parameter
Top rake (°)	29	Tire specifications	4.0-19 59P
Wheel specifications	2.50-19		

Fuel tank volume:

Item	Parameter	Item	Parameter
Main fuel tank (L)	15	Side fuel tank (L)	5

Electrical equipment

Item	Parameter		Item	Parameter
Battery	12V20Ah		Light type	LED
Nominal power of headlamp (W)	12			

Parts introduction(CJ700B-A)

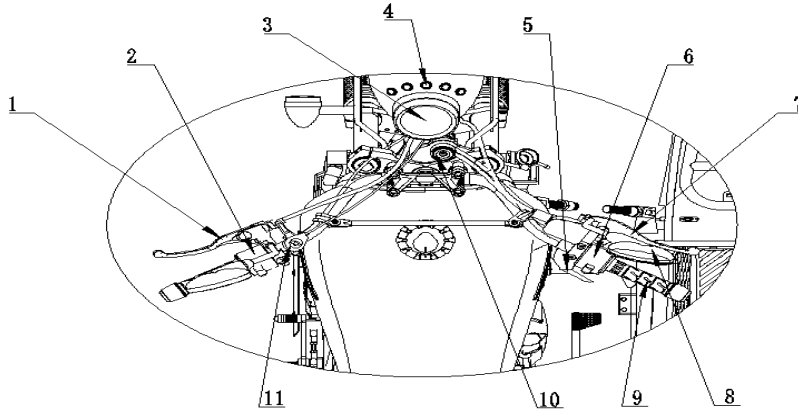

1, CLUTCH HANDLE 2, LEFT SWITCH 3, SPEEDOMETER 4, DRIVING PILOT LAMP
5, PARKING HANDLE 6, RIGHT SWITCH 7, RIGHT BRAKE HANDLE 8, REARVIEW MIRROR
9, HEATING GRIP 10, IGNITION SWITCH LOCK 11, REVERSE LOCK HANDLE

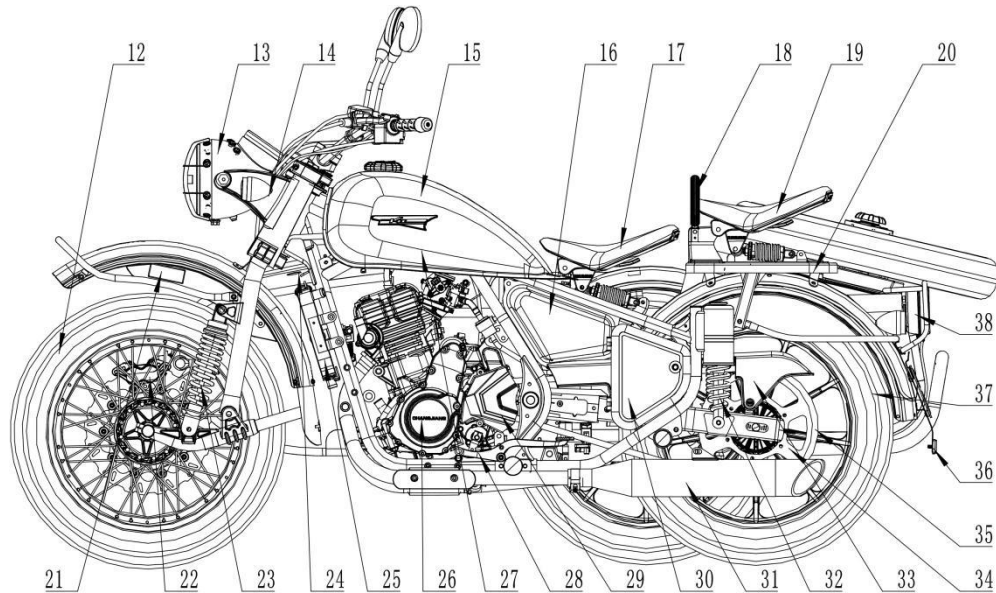

12, FRONT WHEEL ASSY. 13, HEADLIGHT 14, LEFT FRONT TURN SIGNAL 15, MAIN FUEL TANK 16, SECOND FUEL TANK 17, MAIN SEAT 18, ARM REST 19, SEAT 20, REAR SHELF 21, FRONT REFLECTOR 22, FRONT BRAKE 23, FRONT SHOCK ABSORPTION 24, STEERING DAMPER 25, WATER TANK 26, ENGINE 27, AIR FILTER 28, SPEED CHANGE PEDAL 29, LEFT REAR COVER 30, ELECTRICAL BOX 31, EXHAUST MUFFLER ASSEMBLY

32, REAR SHOCK 33, CHAIN HOOD 34, REAR CHAIN DISK 35, DRIVE CHAIN 36, REFLECTOR 37, REAR WHEEL ASSEMBLY 38, REAR TAILLIGHT

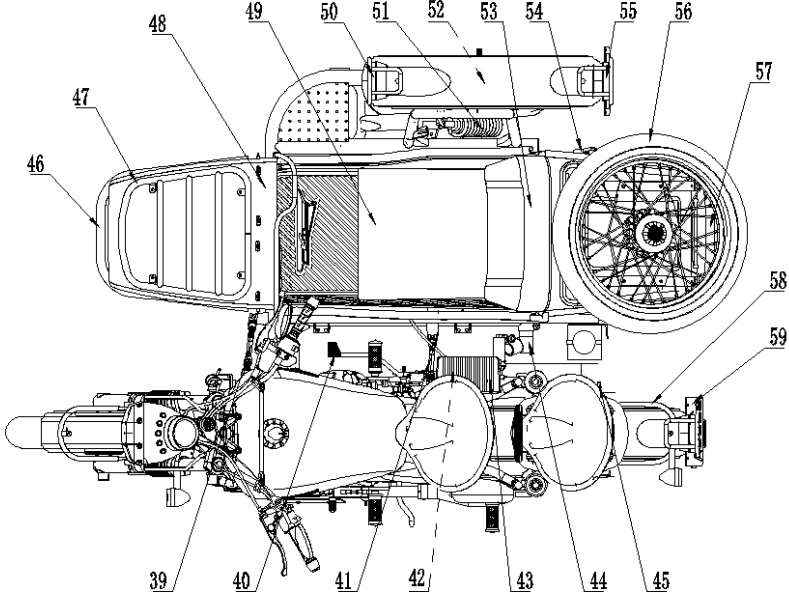

39, FRONT ADJUSTMENT ROD 40, BRAKE PEDAL 41, REAR ADJUSTMENT ROD 42, BATTERY 43, BATTERY BOX 44, CLAMP JOINT 45, REAR BRAKE 46, FRONT BUMPER 47, FRONT SHELF 48, SIDE

BUCKET WELDING ASSEMBLY SIDE SEAT 49, SIDE CAR SEAT 50, RIGHT FRONT LIGHT TURN SIGNAL 51, SIDE SHOCK ABSORBER 52, SIDE WHEEL ASSEMBLY 53, SIDE CAR BACKREST 54, SIDE BUCKET REAR COVER SWITCH 56, RIGHT REAR LIGHT TURN SIGNAL 57, SPARE TIRE 58, REAR BUMPER 59, REAR LICENSE PLATE

Parts introduction(CJ700B-2)

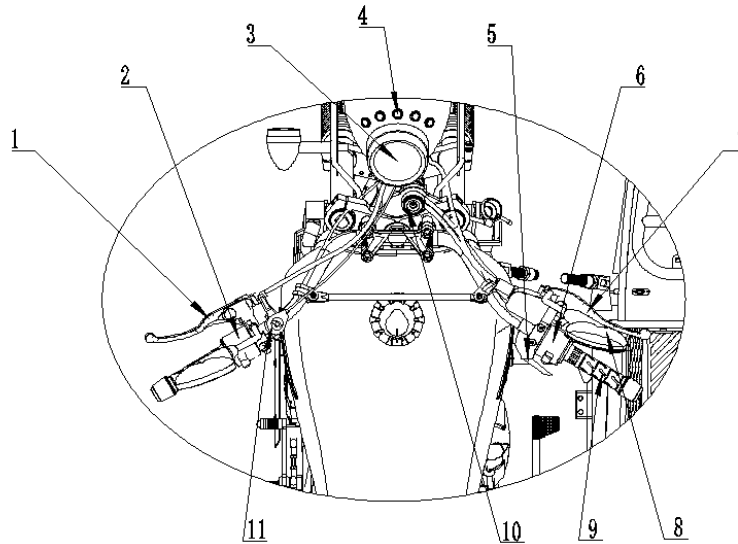

1, CLUTCH HANDLE 2, LEFT HAND SWITCH 3, SPEEDOMETER 4, DRIVING DRIVING PILOT LAMP
5, PARKING HANDLE 6, RIGHT HANDLE SWITCH 7, RIGHT BRAKE HANDLE 8, REARVIEW MIRROR

9, HEATING GRIP 10, IGNITION SWITCH LOCK 11, REVERSE LOCK HANDLE

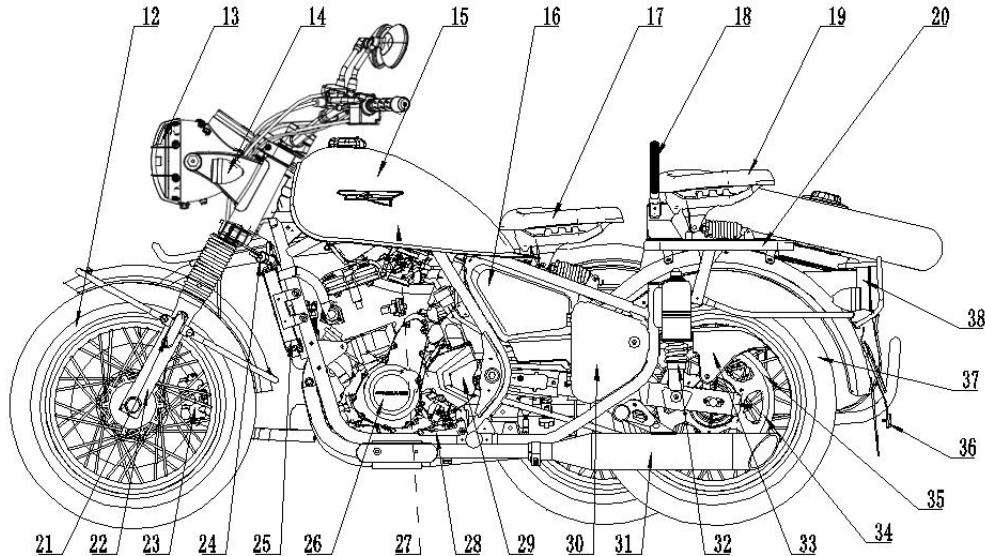

12, FRONT WHEEL ASSEMBLY 13, HEADLIGHT 14, LEFT FRONT TURN SIGNAL 15, MAIN FUEL TANK 16, SECOND FUEL TANK 17, MAIN SEAT CUSHION 18, ARM REST
19, SEAT 20, REAR SHELF 21, FRONT REFLECTOR 22, FRONT SHOCK 23, FRONT BRAKE 24, STEERING DAMPER 25, WATER TANK

26, ENGINE 27, AIR FILTER 28, SPEED CHANGE PEDAL 29, LEFT REAR COVER 30, ELECTRICAL BOX 31, EXHAUST MUFFLER ASSEMBLY 32, REAR SHOCK 33, CHAIN HOOD 34, REAR CHAIN DISK 35, DRIVE CHAIN 36, REFLECTOR 37, REAR WHEEL ASSEMBLY 38, REAR TAILLIGHT

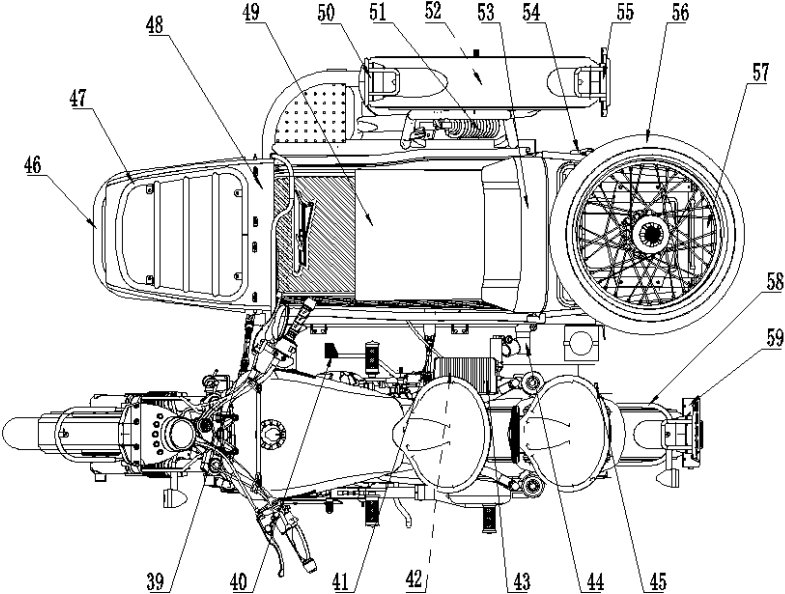

39,FRONT ADJUSTMENT ROD 40, BRAKE PEDAL 41, REAR ADJUSTMENT ROD 42, BATTERY 43,
BATTERY BOX 44, CLAMP PIPE JOINT 45, REAR BRAKE 46, FRONT BUMPER 47, FRONT SHELF 48, SIDE
BUCKET WELDING ASSEMBLY SIDE SEAT CUSHION 49, SIDE CAR SEAT CUSHION 50, RIGHT FRONT
LIGHT TURN SIGNAL 51, SIDE SHOCK ABSORBER 52, SIDE WHEEL ASSEMBLY 53, SIDE CAR
BACKREST 54, SIDE BUCKET REAR COVER SWITCH 56, RIGHT REAR LIGHT TURN SIGNAL 57, SPARE
TIRE 58, REAR BUMPER 59, REAR LICENSE PLATE

Parts introduction(CJ700B-6)

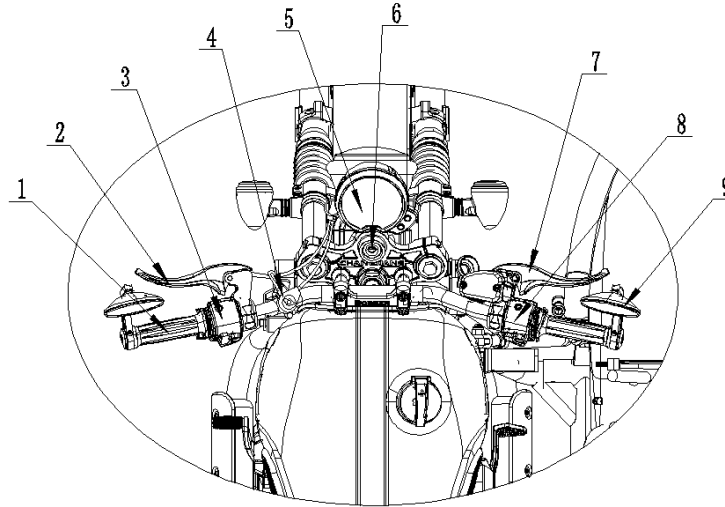

1, HEATING GRIP 2, CLUTCH HANDLE 3, LEFT HAND SWITCH 4, REVERSE LOCK HANDLE
5, SPEEDOMETER 6, IGNITION SWITCH LOCK 7, RIGHT BRAKE HANDLE 8, RIGHT HAND HANDLE
SWITCH
9. REAR VIEW MIRROR

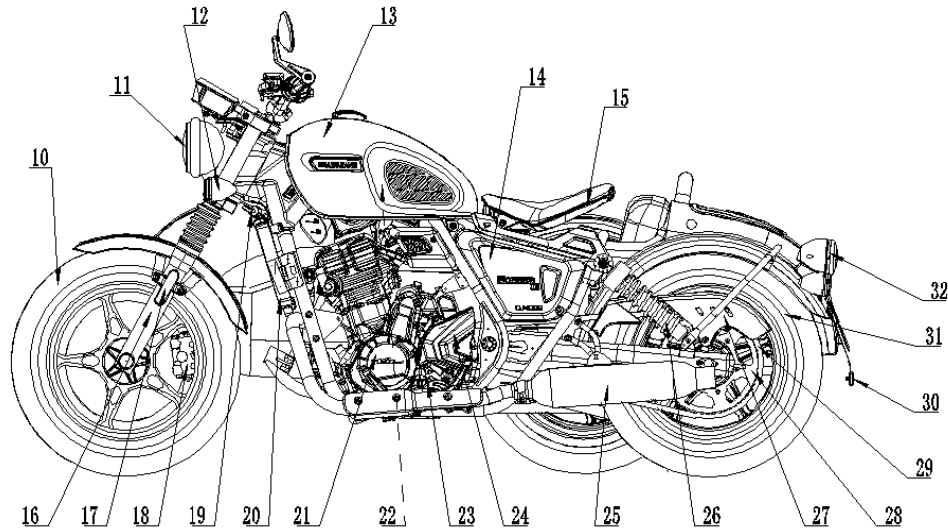

10, FRONT WHEEL ASSEMBLY 11, HEADLIGHT 12, LEFT FRONT TURN SIGNAL 13, FUEL TANK 14, LEFT COVER 15, MAIN SEAT CUSHION 16, FRONT SHOCK ABSORPTION 17, FRONT REFLECTOR 18, FRONT BRAKE 19, STEERING DAMPER 20, WATER TANK 21, ENGINE 22, AIR FILTER 23, SPEED CHANGE PEDAL 24, LEFT REAR COVER 25, EXHAUST MUFFLER ASSEMBLY 26, REAR SHOCK 27, CHAIN COVER 28, REAR CHAIN DISK 29, DRIVE CHAIN 30, REAR REFLECTOR 31, REAR WHEEL ASSEMBLY 32, REAR TAILLIGHT

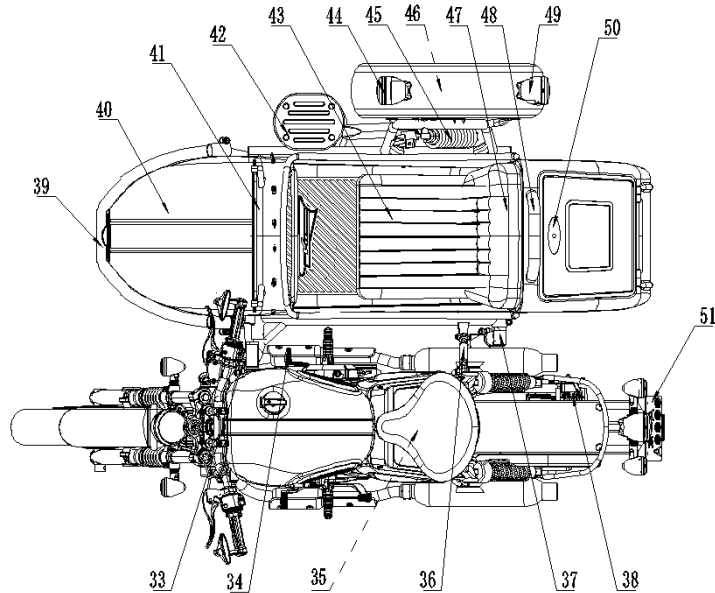

33, FRONT ADJUSTMENT ROD 34, BRAKE PEDAL 35, BATTERY 36, REAR ADJUSTMENT ROD 37, STUCK PIPE JOINT 38, REAR BRAKE 39, SIDE BUCKET FRONT BUMPER 40, SIDE BUCKET WELDING ASSEMBLY 41, SIDE BUCKET FRONT WINDSHIELD 42, SIDE CAR PEDAL 43, SIDE CAR SEAT CUSHION

44, SIDE CAR HEADLIGHT 45, SIDE SHOCK ABSORPTION 46, SIDE WHEEL ASSEMBLY 47, SIDE CAR BACKREST 48, REAR ANTI-ROLL SUPPORT 49, SIDE CAR REAR LIGHT SIDE BUCKET BACK COVER SWITCH LOCK 51, REAR LICENSE PLATE

Loading and attachment information



Incorrect loading or improper modification of the car or improper installation accessories or maintenance may cause driving safety hazards; Before driving, make sure the car is not overloaded and follow these instructions.

Always use Changjiang original parts and our approved accessories. If you choose non-original Changjiang parts, improper installation accessories and improper loading, etc., the vehicle performance will be affected, and even the requirements of the regulations will be violated. Please note that you must be responsible for your own safety and the safety of others.

 **NOTE**

The parts and accessories we have configured for this vehicle have been specially designed and verified, so we strongly recommend that you use the original Changjiang parts and install our approved accessories.

The change of the weight of the whole motorcycle has a great impact on the dynamic performance of the whole motorcycle, so you must accept the load weight, the number of passengers and the installation accessories specified by us.

Before driving, you should pay attention to the following basic matters

1. any occupant must be very familiar with the particularity of side three-wheel motorcycle driving, right turn easy rollover, must pass at a low speed.
2. The passenger should sit on the passenger seat as smoothly as possible during driving, and the driver's control should not be affected.
3. In order to reduce the impact on the motorcycle's center of gravity, all luggage carried on the motorcycle must be as low as possible. Luggage should be avoided sticking out of the back of the motorcycle too long.
4. The baggage must be securely fastened to the motorcycle. Please make sure that the baggage cannot be moved before driving. When the motorcycle feels unstable, the luggage should be re-checked for firmness, and readjust if necessary.
5. Do not carry heavy or bulky luggage. Overloading will definitely affect handling and power performance.

6. Do not install accessories and carry baggage that reduce the performance of the motorcycle. Make sure that what you do will not affect any lighting system, ground clearance, braking performance, roll Angle, handling performance, tire compression travel, front fork working travel or other relevant motorcycle driving performance.
- 7, the hand handle or front fork weight will affect the steering performance, and can cause unsafe driving factors.
8. Cowls, windshields, backrest and other large components affect the stability and handling performance of the motorcycle. They not only increase the weight, but also reduce the power performance when the motorcycle is driven. Lack of design validation, it may cause unsafe factors after installation. It will cause unsafe factors.
9. The engine installed in the vehicle has the reverse function, which can make the vehicle quickly pour out in the place where it is inconvenient to turn around, saving time and effort.

Maximum load: No more than 225kg (including driver, luggage and accessories).

Speedometer Assy.(CJ700B-A/CJ700B-2):

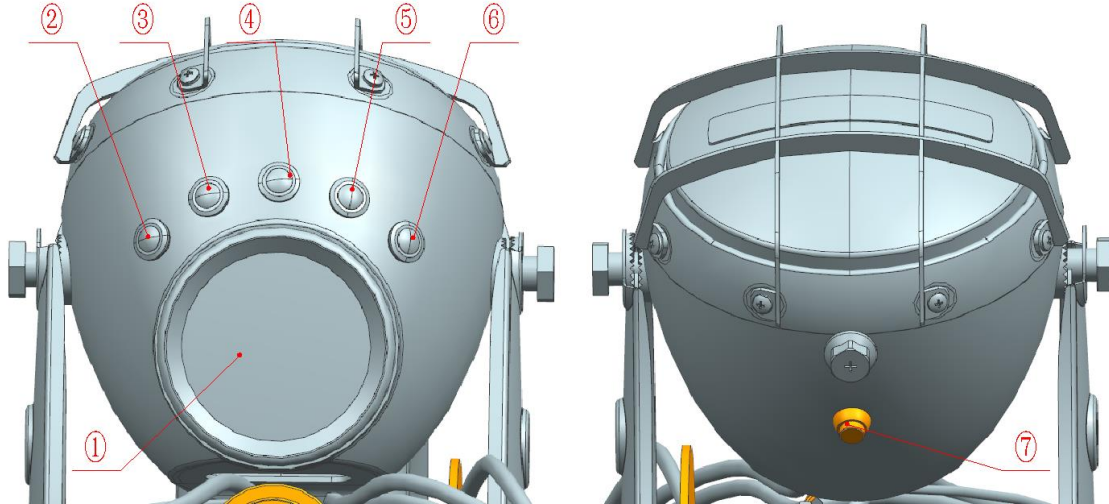

①, INSTRUMENT PANEL ②, LEFT INDICATOR ③, HIGH BEAM INDICATOR ④, NEUTRAL INDICATOR ⑤, FAULT INDICATOR ⑥, RIGHT INDICATOR ⑦, RESET/SUBTOTAL BUTTON

CHANGJIANG CJ700B-A/CJ700B-2 Speedometer operation instruction

一、Speedometer display and function introduce

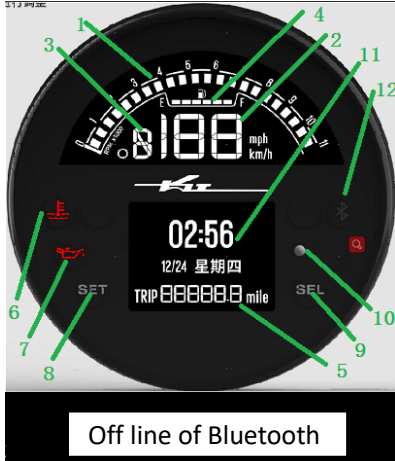

Off line of Bluetooth

Figure 1 press the SET key to clear the subtotal mileage;

1. Speed display: Show Engine speed;
2. Speed display: Show the current speed, press SEL button to select between Km/h and mph;
3. Gear display: Show the gear position of the current vehicle;
4. Fuel indicator: shows the fuel amount in the fuel tank, full fuel for 6, when the oil gauge only 1 grid indicates that the fuel amount in the fuel tank is insufficient, please replenish the fuel in time;
5. Total/subtotal mileage display: display the total mileage and subtotal mileage of the vehicle. Press the SET key to switch between the two. Under the subtotal state, long press the SET key to clear the subtotal mileage;
6. Water temperature alarm lamp: When the water temperature reaches 120°C, the water temperature alarm lamp will light up;
7. oil pressure alarm lamp: when the oil pressure is insufficient, but it should be noted that before opening the key switch and not starting, the lamp is on as a normal phenomenon, and the lamp will be out after starting;
8. SET button: Under the normal interface: short press total and subtotal mileage to switch, and long press subtotal mileage to clear zero under subtotal state;

The status without Bluetooth connection is shown in Figure 1;

The functions of each part on the display are described as follows:

9. SEL button: Under normal interface: short press to switch to British system and long press to enter clock setting mode;
- 10, Speedometer sensitive collection point: when the light dimmed, Speedometer output sensitive signal, light up the vehicle near light and position light;
11. Time and date display: Show the current date and time. In normal interface, long press SEL key to enter clock setting mode, short press SET to shift, short press SEL key to add, short press SET key to save and exit after setting; When the Speedometer is connected to the phone's Bluetooth, the time and date can be automatically calibrated.
12. Bluetooth connection mark: When the Speedometer successfully connects to the Bluetooth of the phone, the mark turns blue.

Description of interconnect mode between meter and mobile phone

Mobile phone interconnect mode, can achieve car search, mobile phone on-screen navigation, listening to music and call tips and other functions. Here's how to connect your phone;

- 1、 Download the “Motofun”APP from the mobile APP market, Click on all the options, install it and get into the APP to work;
- 2、 Once in the APP, Click the Bluetooth connection shown in figure 2;
- 3、 When the Bluetooth is not open, you will be prompted to ask the Bluetooth to open. Choose “Allow”to open the Bluetooth;

4、As the phone approaches the meter, click on “FSC-BT966C-LE” in the Bluetooth signal to connect, as shown in figure 3 and figure 4;

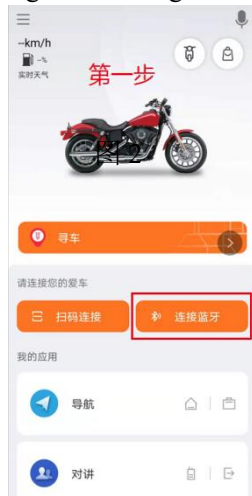

Figure 2

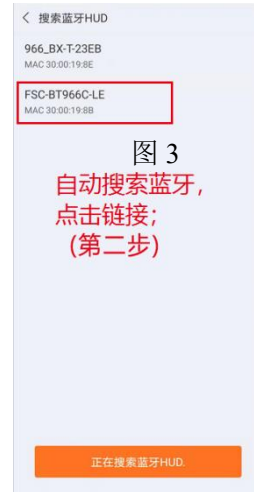

Figure 3



Figure 4

5、Click on the Bluetooth Connection icon to enter the Bluetooth settings screen, as shown in figure 5, Select “FSC-BT966C” audio Bluetooth connection, after connecting as shown in figure 6 click settings;

6、Open all settings in the settings screen as shown in the following figure;

7、Go back to the MOTOFUN APP's main screen, Click find the car, enter your phone number and Verification Code in the subsequent login screen, Click login and a map containing the location of the car will pop up, click navigation, music, etc. , the instrument then enters the corresponding interface, at this time if there is a phone call in the instrument will show below the calling number



Figure 5

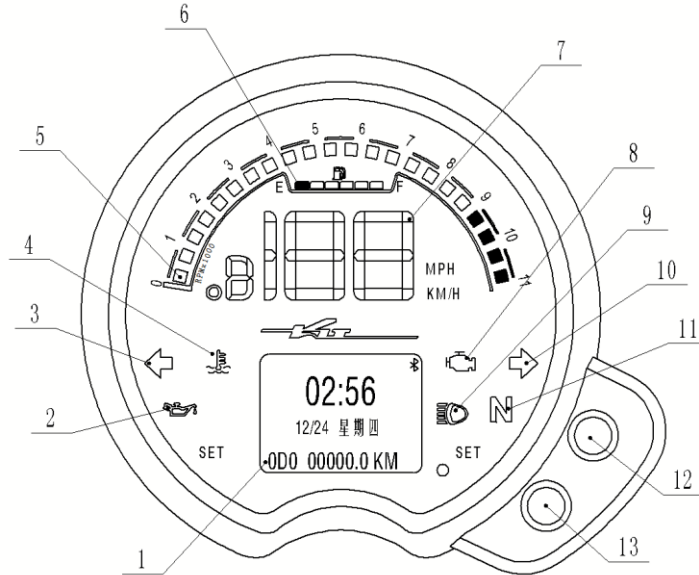

Figure 6



Figure 7

Speedometer Assy.(CJ700B-6):



TOTAL MILEAGE/SUBTOTAL MILEAGE 2. ABS ALARM LAMP 3. OIL ALARM LAMP 4. LEFT TURN INDICATOR LAMP 5.
 WATER TEMPERATURE ALARM LAMP 6. ENGINE TACHOMETER 7. FUEL DISPLAY 8. SPEED DISPLAY 9. FAULT

INDICATOR LAMP 10. HIGH BEAM INDICATOR LAMP 11. RIGHT TURN INDICATOR LAMP 12. NEUTRAL LAMP 13.
KEY S1 14. KEY S2

Total mileage/subtotal mileage 1

It is needed to short press S2 to perform the switching of the total mileage and subtotal mileage.

ABS alarm lamp 2

In case of a fault of the ABS system, the ABS alarm lamp will lighten.

In case the ABS alarm lamp lightens, please contact your dealer for inspection and maintenance.

Oil alarm indicator lamp 3

When the key switch is turned on but the engine is not started, the oil alarm lamp always lightens. After the engine is started, the oil alarm lamp should go out. In case the alarm lamp lights, it indicates that the oil quantity is lower than the requirements and it is necessary to add oil promptly.

Left turn indicator lamp 4

When the left turn switch “” on the left handlebar switch is pressed, the left turn indicator lamp will lighten. When the left turn switch is pressed again, the indicator lamp will go out.

Water temperature warning lamp 5

When the water temperature of the engine exceeds 110°, the water temperature alarm lamp will lighten.

Engine tachometer 6

The engine tachometer shows the current engine rotation speed (r/min). There is a “red area” on the right side of the tachometer. The pointer of the tachometer in the red area indicates that the engine rotation speed is beyond our recommended engine rotation speed and is also out of its optimum operating range.

When the ignition switch is turned to “

Fuel indication 7

Display the fuel volume in the fuel tank. When the full display of 5 grids of fuel volume indicates that the fuel tank is full. When there is only one grid left and the oil level starts to flash, it indicates that the fuel tank is insufficient (less than 3L). It is necessary to add fuel promptly. When the fuel symbol “

When the “

Speed display 8

Display the current driving speed. When the driving speed shows \geq “109”, it means that your current speed has exceeded the designed maximum speed of the vehicle and it is needed to reduce the speed promptly.

Fault indicator lamp 9



When the ignition switch is turned to the “

When “

27

dealer for inspection and maintenance

High beam indicator lamp 10

When the right handlebar switch is turned to the “” position and the dimmer switch is turned to the “” position, the high beam indicator lamp will lighten.

Right turn indicator lamp 11

When the right turn switch “” on the right handlebar switch is pressed, the right turn indicator lamp will lighten. When the right turn switch is pressed again, the indicator lamp will go out.

Neutral indicator lamp 12

When the engine is in neutral, the neutral indicator lamp will lighten.

Key S1

1. It is needed to short press S1 in the normal interface to perform the switching of the metric system and British system.
2. In case of pressing S1 for over 3 seconds in the normal interface, the subtotal mileage will be reset.
3. Press S1 to turn on the ignition key (power on) and enter the password input interface. Then, release S1 and short press S1 for the corresponding digit changes from 0 to 9. Later, long press S1 for more than 3 seconds to move to the next digit while the next digit flashes. After inputting the password, press S1 for more than 3 seconds to enter the parameter setting interface. Adjust the corresponding parameters in the same way. After the parameters are

adjusted, it is needed to long press S1 for more than 3 seconds to enter the normal interface of the instrument. The parameter is adjusted successfully at this time.

Key S2



1. It is needed to short press S2 in the normal interface to perform the switching of the subtotal / total mileage.

Turn off the main power
Turn on the main power
Lock the direction

key set

It is important to use the key to turn on the ignition switch / directional lock and fuel tank cover. So, you must keep the key well and store the spare key in a safe place so that the key can be duplicated in case of loss. Otherwise, you can only replace the whole set of locksets.

Ignition switch / directional lock

The ignition switch is equipped with “”, “”, “” and other positions.

 : The engine can operate and all circuits of the vehicle are connected.

 : The engine cannot operate and all circuits of the vehicle are disconnected.

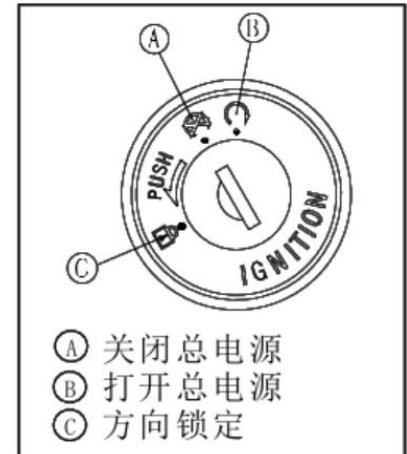



: The direction handle is locked and all circuits of the vehicle are disconnected to prevent vehicle theft.

 **WARNING**

As long as the key is turned to "  " position, the signal light, taillight, license plate light can be turned on. When the headlight is turned on, it is best to keep the engine in working state to avoid battery loss. When the engine is down, do not light for a long time, otherwise it may cause battery power loss or damage to the battery.

Right handlebar switch(CJ700B-A/CJ700B-2)



ENGINE TURN OR OFF BUTTON LIGHTING SWITCH STARTING BUTTON

Engine turn or off button ①

Please set on “ ”  is when need to drive.

The Engine flameout switch is used in case of emergency. If an emergency needs to shut down the engine, please set on “ ” status 

 **NOTE**

Although the engine can be stopped by using the flame-out switch, it cannot disconnect all the circuits, and usually the engine must be stopped by using a key.

Lighting switch②

Lighting switch include: “  ‘  ” ●

 : When in this position, the headlight, position light, license plate light and Speedometer light can be lit.

 : In this position, the position light, license plate light and Speedometer light can be lit.

● : When in this position, the headlights, position lights, license lights and Speedometer lights are off.

Starting button③

When the key is in the “” position and the gear is in the neutral gear, it is feasible to directly press the starting button to start the engine. When the gear is in other gears, it is needed to hold the clutch switch and press this button at the same time to start the engine.

Right handlebar switch(CJ700B-6)

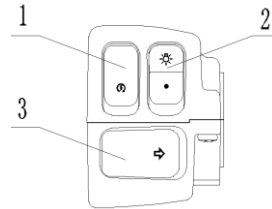

1 STARTING BUTTON 2 LIGHTING SWITCH 3 RIGHT TURN SWITCH

Starting button 1

When the key is in the “” position and the gear is in the neutral gear, it is feasible to directly press the starting button to start the engine. When the gear is in other gears, it is needed to hold the clutch switch and press this button at the same time to start the engine.

Lighting switch 2

Lighting switch includes “”, “” and other positions.

 : When it is set in this position, the headlamp, position lamp, license plate lamp and instrument backlight can be lightened.

● : When it is set in this position, the headlamp, position lamp, license plate lamp and instrument lamp are turned off.

Right turn lamp switch 3

In case of pressing “”, the right turn lamp and the right turn indicator lamp on the instrument flash and lighten. In case of pressing it again, the above lamps go off.

Left hand PC switch(CJ700B-A/CJ700B-2)

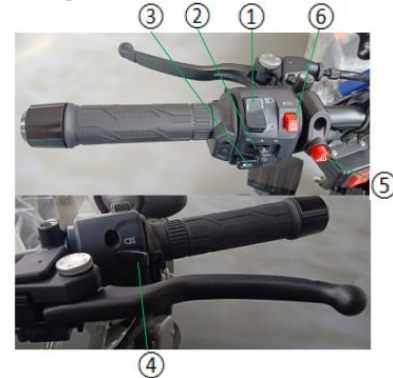



DIMMER SWITCH □ TURN SIGNAL SWITCH □ HORN BUTTON □ PASS LIGHT SWITCH □ EFI STATUS SWITCH □ WARNING SWITCH

Dimmer switch 1



The dimmer switch includes “” “” and other positions.



 : When it is set in this position and the lighting switch is set to “ ” position, the high beam lamp of the headlamp and the high beam indicator lamp on the instrument lighten.

 : When it is set in this position and the lighting switch is set to the “” position, the low beam lamp of the headlamp lightens.

Turn signal switch②

Include: “  “ ”、● ” 

 : When this button is pressed, both the left turn signal and the left turn indicator on the Speedometer flash on.

● : Press this button to turn off the turn signal.

 : When this button is pressed, both the right turn signal and the right turn indicator on the Speedometer flash on.

Horn button 3

In case of pressing the ‘’ button and the horn will make a sound.

Pass light switch④

When the driver needs to pass car, press this button at intervals to make the high-beam signal to pass, and the high-beam indicator light on the Speedometer is also lit at intervals.



WARNING

If you keep the turn signal and Speedometer indicator flashing for more than 30 minutes when the engine is not running, it is easy to cause battery loss or damage to the battery.

EFI status switch **⑤**



Used to switch engine working status (normal or sport)



Warning switch **⑥**



In case of accident or other emergency, press the warning switch and all the turn signals will shine.

Left handlebar switch (CJ700B-6)

Dimmer switch 1

The dimmer switch includes “ ” “ ” and other positions.

 : When it is set in this position and the lighting switch is set to “ ” position, the high beam lamp of the headlamp and the high beam indicator lamp on the instrument lighten.

 : When it is set in this position and the lighting switch is set to the “ ” position, the low beam lamp of the headlamp lightens.

Left turn lamp switch 2

In case of pressing “ ”, the left turn lamp and the left turn indicator lamp on the instrument flash and lighten.

Horn button 3

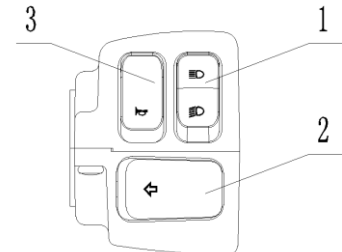

In case of pressing the “ ” button and the horn will make a sound.



WARNING

If you keep the turn signal and Speedometer indicator flashing for more than 30 minutes when the engine is not running, it is easy to cause battery loss or damage to the battery.

Warning function

In the event of an accident or other emergency, it is needed to press the left handlebar “” and the right handlebar “” switch at the same time and all steering lamps will flash, which plays the roles of prompting, warning and caution. It is important to press the left and right turn switches at the same time to turn off the turn lamp.

Left heating handlebar sleeve

Heating indicator lamp

Heating control switch

Heating handle sleeve

The heating handle sleeve can only be turned on after the engine is started. When the power is on, the indicator lamp on the left heating handle sleeve will turn green and flash three times, indicating that the function is normal. In case the color is blue, it indicates that the protection function does not operate, but it can perform the normal



①左加热手把套 ②加热控制开关 ③加热指示灯

heating. At this time, it is needed to implement the maintenance and replacement promptly. In standby status, in terms of pressing the button on the handle sleeve, in case the power supply voltage is lower than 12.9V, the red indicator lamp will flash several times to enter the standby status. In case the power supply voltage is higher than 12.9V at this time, the system will enter into rapid heating. Each time the button is pressed, the electric heating power will increase by 20%. There are 5 gears in total and the colors of the indicator lamp are blue- cyan-green-purple-red.

In the operation status, the power supply voltage is lower than the electric heating starting voltage and the corresponding gear indicator lamp flashes. At this time, in case the voltage is lower than this voltage for 7 seconds, the controller will cut off the electric heating output and enter the standby status. In case the normal voltage is restored within 7 seconds, the indicator lamp will always lighten and enter into normal operation.

Adjustment of brake/clutch handle

The brake handle and clutch handle have adjusters, adjust the position of the handle to suit the operation of different drivers.

Just rotate the regulator.

Adjustable distance range of handle handlebars: 85mm ~ 100mm.



Parking brake handle (CJ700B-A/CJ700B-2)

Parking brake handle have include the“ON Parking”“OFF Parking”ect.

ON Parking: When the handle is turned to this position, the vehicle is in the parking brake state.

OFF Parking: When the handle is turned to this position, the vehicle is in the non-parking brake state.

WARNING

After engine ignition and before driving, be sure to turn the Parking brake handle to the "OFF Parking" position.

Before engine shutdown and after braking, be sure to turn the Parking brake handle to the "ON Parking" position.



驻车手柄

Parking brake handle

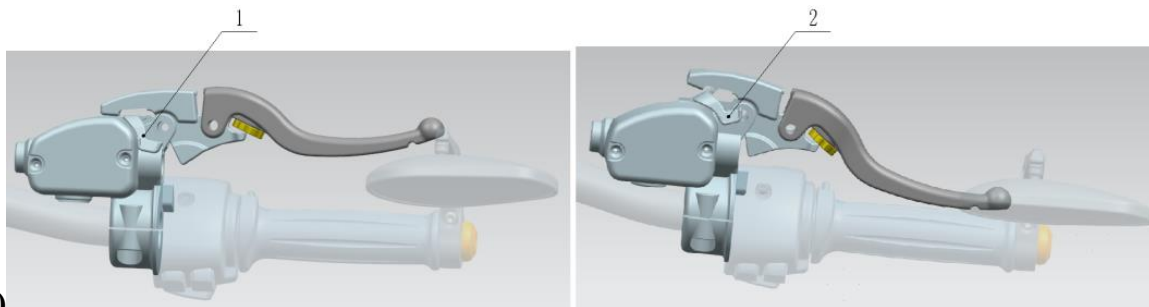

(CJ700B-6)

When the handle is in position 1, the vehicle is in non-parking brake status.

When the handle is in position 2, the vehicle is in the parking brake status.

!WARNING

After engine ignition and before driving, make sure to hold the right brake handle so that the parking brake handle is in 1 position.

Before engine shutdown and after braking, be sure to turn the parking brake handle to position 2.

Steering damper

40



調整按鈕

All cars are equipped with steering dampers.
Steering damper greatly provides motorcycle high-speed stability and safety.
The damping size of the steering damper can be adjusted to adapt to different driving requirements.
Turn the adjusting knob clockwise to increase damping. Counterclockwise rotation, damping decreases
Small.



WARNING

Excessive damping adjustment may cause a turning hazard, which may result in damage and injury.

Electric box

Insert the key and turn it counterclockwise to open the electrical box.

ECU (electronic control unit) 1

ECU: It is the abbreviation of the electronic control unit. It is actually an integrated circuit board. The manufacturer has set a reasonable control program and data for ECU. The fuel injection of the injector and the ignition of the high-pressure coil are both controlled by detecting the

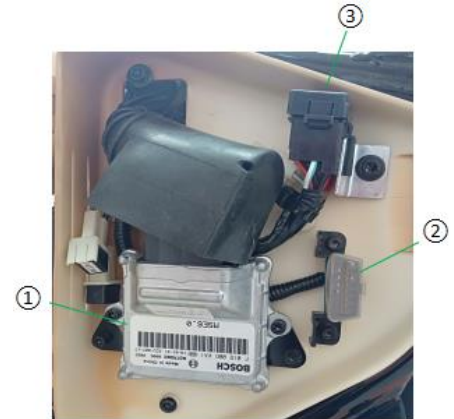

①ECU ②诊断接口 ③保险丝盒

signals from all sensors so that the engine can obtain the best fuel injection volume, injection time and ignition time under various operating conditions. Later, the requirements of output torque, low fuel consumption and emission warranty can be met. Meanwhile, ECU also has the function of system fault diagnosis. In case of a fault in a link or an incredible signal value, ECU will set fault information record in RAM fault memory promptly. The fault information record is stored in the form of fault code and displayed in the order of fault occurrence. The fault can be divided into “current fault” and “historical fault”. During maintenance, the fault components can be quickly found through the diagnostic instrument and fault indicator lamp, which improves maintenance efficiency and quality.



Please don't modify the preset control procedure and data of ECU without authorization, which may affect the motorcycle performance, or even cause the motorcycle failure or damage.

Diagnostic interface 2

Pull out the plastic cover of the diagnosis interface and connect the interface of the diagnostic instrument and diagnosis interface.

Judge the cause of the fault in accordance with the fault code of the diagnostic instrument (See the comparison table of fault code of the electronic fuel injection system for details) and implement the maintenance.

 **WARNING**

Do not handle the motorcycle fault by yourself, otherwise it is easy to cause safety risks or accidents.

Fuse box 3

In case the fuse is blown, it is needed to check whether there is a fault in the electrical system and replace it with a new fuse with the same ampere after repairing the fault. It is forbidden to connect the corresponding wire directly over the fuse. Similarly, it is forbidden to use other wires to replace the corresponding fuse.

 **DANGER**

Do not use any wire to replace the corresponding fuse, replace with a new fuse of the same ampere. The corresponding amperes are marked on the fuse.

Fuel tank cap

Open the fuel tank cap, turn the keyhole cover, insert the key and turn it clockwise. Lock the fuel tank cap, insert the key into the cap, and press the cap into the fuel

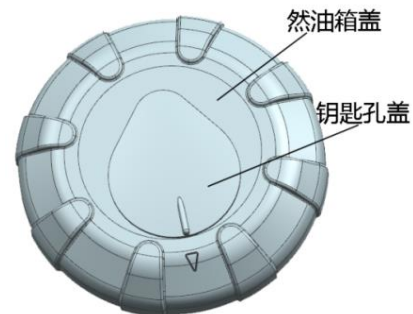

The key will automatically return to the box, and you can pull out the key.

 **NOTE**

When the key is not inserted, the fuel tank cap cannot be locked, and the key can only be pulled out when the fuel tank cap is safely locked. Do not push on the key when the fuel tank cap is locked or the cap does not lock.

Fuel tank

When adding fuel to the fuel tank, the oil surface should not exceed the bottom surface of the oil cup at the refueling port. Try to avoid the fuel flowing out of the fuel tank or handle the fuel flowing out of the fuel well to prevent the fuel from causing pollution and danger.

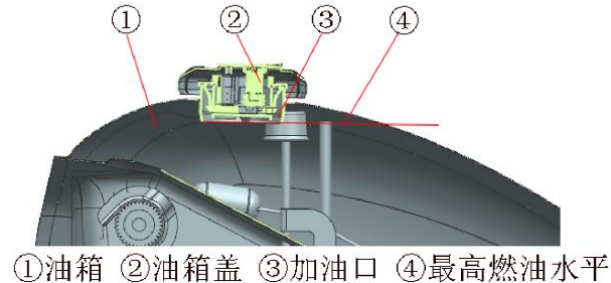

 **DANGER**

Gasoline is very easy to burn and explode under certain conditions, so when adding fuel, the ignition switch must be set in the "  " position, do not smoke, determine the area is well ventilated and no spark and other flame, also including the maintenance of the working lamp. Do not add fuel level to underside of refueling port. After filling, make sure the fuel tank cap is securely locked. For example, when the fuel spills out of the fuel tank, it should be wiped off immediately.

Fuel oil requirement

This car is only suitable for This car is only suitable for unleaded petrol No.92 or above.

 **WARNING**

Do not use leaded gasoline. Using leaded gasoline will destroy the catalytic converter. (For further understanding, please refer to the information on catalytic converters)

Octane value rating

The higher the octane rating of gasoline, the stronger the ability to inhibit engine knocking or cylinder knocking. Be sure to use unleaded gasoline with an octane rating of 92 or above.

 **NOTE**

Use premium or higher octane unleaded gasoline if the engine is knocking or knocking.

Adjustment of rearview mirror

It is needed to loosen the hexagon bolt in the inner hole of the end face of the direction handle and rotate the rearview mirror to adjust the viewing angle. After adjustment, it is important to tighten the hexagon bolt. The adjustment methods of left and right rearview mirrors are the same.

 **WARNING**

When installing and removing the rearview mirror, do not use too much force to avoid damaging the rearview mirror bracket.

Front adjustment pull rod/Rear adjustment pull rod

The camber Angle of the main car can be adjusted by rotating the lead screw to adjust the length of the front and rear pull rods.

When rotating clockwise, the length of the tie rod becomes shorter and the camber Angle becomes smaller, whereas the camber Angle becomes larger.

The camber Angle of this side three-wheeled

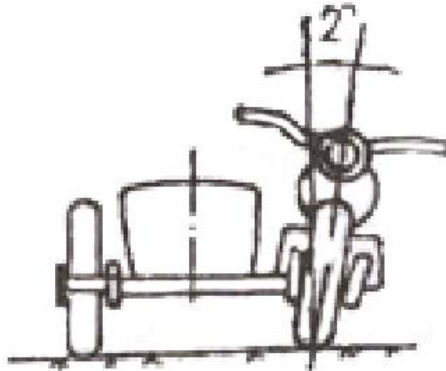

motorcycle is 2°



WARNING

In order to drive safely, the side of the three-wheeled motorcycle needs to have a certain camber Angle, do not adjust at will, in order to avoid rollover accident.

Stuck pipe joint

Adjust the embedment length of the clamp joint and adjust the front beam of the side car.

The front beam of this side three-wheeled motorcycle is 15mm.



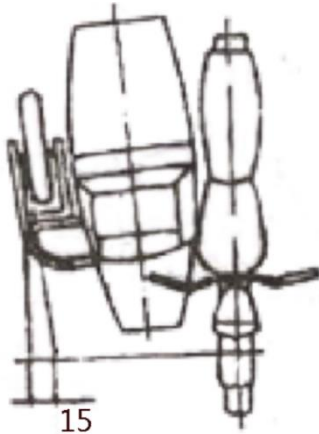

 **WARNING**

In order to drive safely, the side three-wheeled motorcycle needs to have a certain front bundle, do not adjust at will, in order to avoid rollover accident.

Sidecar switch combination(CJ700B-A/CJ700B-2)



① CIGARETTE LIGHTER /12V VEHICLE POWER CONNECTOR ② VOLTAGE/AMMETER ③ USB CONNECTOR ④ SPOT LIGHT SWITCH ⑤ FOG LIGHT SWITCH

Cigarette lighter /12V vehicle power connector①

When in use, open the cover, the connector provides 12V direct current.

⚠ NOTE

Be sure to cover it after use to avoid short circuit and circuit failure caused by water.

voltage/ammeter ②

Displays the current battery voltage of the vehicle and the current through the cigarette lighter or 12V power connector.



When the voltmeter shows voltage below 12.8V, the battery should be charged with a charger.

USB connector ③

When in use, open the cover and provide two USB connectors: 5V 1A and 5V 2.1A.



Check whether the rated voltage and current of the appliance are consistent with the voltage of the connector during use to avoid damage to the appliance.

Spot light switch ④

The adventure and police versions are equipped with spotlights.

Press the switch "●" point, spotlights on.

Fog light switch ⑤

The adventure and police versions are equipped with fog lights.

Press the switch "●" point, fog light on.

Sidecar switch combination(CJ700B-6)

Front fog light switch

Press the switch "●" point, fog light on.

USB connector

**When in use, open the cover and provide two USB connectors:
5V 1A and 5V 2.1A.**

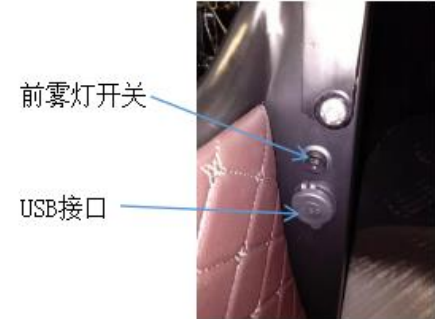

⚠ WARNING

Check whether the rated voltage and current of the appliance are consistent with the voltage of the connector during use to avoid damage to the appliance.

Side bucket rear

cover lock

Lock the back cover of the side bucket: hold down the handle of the side bucket lock to the lock state, rotate the lock core with the key to the lock state, release the handle to complete the lock of the back cover.

Open the back cover of the side bucket: gently press the handle of the side bucket lock downwards, rotate the lock core with the key to the unlocking state, release the handle to open the back cover.

Spare tire

The car is fully equipped with a full-size spare tire.

Take out the spare tire: First turn the spare tire cover counterclockwise, remove the cover and take out the spare tire.



Make sure the spare tire is in good condition and has sufficient air pressure for emergencies.

TOOL

The tool is in the side bucket trunk.

You can use these tools to make simple repairs and adjustments to your car.

Tool include:

Name	QTY	Name	QTY	Name	QTY
Open end wrench 8-10	1PC	Internal hexagonal wrench 5	1PC	Cross screwdriver6*100	1PC
Open end wrench 12-14	1PC	Internal hexagonal wrench 6	1PC	Spark plug sleeve16#	1PC
Open end wrench 13-15	1PC	Internal hexagonal wrench 10	1PC	Nipper pliers 6inch	1PC
Open end wrench 24-27	1PC	Flat-head screwdriver6*100	1PC	Spare tire cover wrench	1PC

Running-in

The running-in period of the vehicle is the first time to drive 1500km. Regular maintenance shall be implemented according to the provisions of the running-in period. During the running-in period, the following provisions must be followed:

- The recommended maximum engine rotation speeds during the running-in period are as follows:

Total vehicle mileage	Maximum engine rotation speed
0km~800km	4000r/min
800km~1500km	6000r/min

- It is forbidden to press the starting button while driving and operate the engine at high speed promptly at the beginning of starting. Even after the engine is heated, it should run at idle speed for 2-3 minutes to let the lubricating oil enter all lubricating components of the engine.
- When in neutral gear, it is forbidden to let the engine operate with a too high rotation speed.



New tires have a slick tread and can cause loss of control and injury. The specified tire pressure must be guaranteed during the 1500km run-in period. Avoid braking or braking too hard, sudden acceleration or sharp turns during the run-in period.

Please consult your dealer for important maintenance services during the run-in period.

How to drive the vehicle

Start the engine

- Retract the side stand.

- Turn the key to the “” position.
- Make sure the gear is in neutral.

 **WARNING**

Do not press the start button for more than 5 seconds continuously, otherwise the starter motor will be overloaded or the battery will lose power. Wait 15 seconds before pressing the start button.

 **NOTE**

The car is equipped with a clutch switch, when the engine needs to start, hold the clutch handle to start the engine.

 **WARNING**

Do not let the engine idle for more than 5 minutes in place for a long time, otherwise it will allow the engine to overheat or damage other parts.

Starting Engine quickly

If the battery is out of power, it must be removed and charged. If you need to start the engine urgently, you can use 12V power supply to start the engine quickly.

DANGER

Under certain conditions, hydrogen gas produced by battery electrolyte is easy to burn and explode. It will accumulate in the battery and even leak out. Ensure that the workplace is well ventilated and free of flame or electrical sparks (including lit cigarettes) nearby. Wear safety goggles when working with batteries. If electrolyte spills on skin, eyes or clothing, rinse immediately with plenty of water and see a doctor.

- Follow the standard procedure for starting the engine.

WARNING

When starting, do not press the start button for more than 5 seconds. Otherwise, the starter motor will be overloaded or the battery will lose power. Wait 15 seconds before pressing the starting button to cool and restore the battery power.

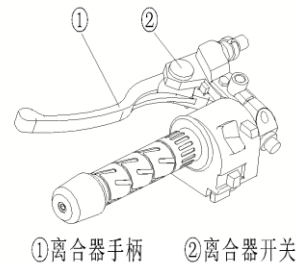

Get ready to drive

- Hold the clutch handle tightly.
- Switch to first gear. Open the accelerator slightly and release the clutch handle slowly.
- When the clutch is fully engaged, it is feasible to step on the gas a little more.
- Please make sure that there is enough fuel to keep the engine operating.

Shift gears

- Release the throttle before gripping the clutch handle.
- Use the shift lever to select the desired gear.
- The tank is labeled with the mark gear.



When it is necessary to change gear, the engine speed should be reduced first, otherwise it will damage the engine, and may cause rear wheel slip and other accidents. The engine speed must be controlled below 5000r/min when shifting gears.

- The throttle slowly increases while the clutch handle is released.

⚠ 注意/CAUTION

- 经常保养/Maintain regularly
 - 国际档/International standard gear
 - 佩戴头盔/ Always wear helmet
 - 安全驾驶/Ride safely
 - 驾驶前请仔细阅读说明书/Please read the instructions carefully before driving
- Ⓜ--Ⓝ--①--②--③--④

⚠ 警告/WARNING

加油时，汽油油面不要超过加油口油杯底部。
When refueling, do not exceed the bottom of the fuel cup



Reverse gear

- Use the shift lever to keep the engine gear in neutral.
- Turn the shift handle backward with your left hand so that it is in reverse position.
- Step on the shift lever counterclockwise to make the engine gear in reverse position.

Observe the road conditions and reverse the vehicle.

- After reversing, put the engine gear in neutral and move forward with your left hand
- Move the shift handle so that the handle is in the normal driving position and step on it clockwise
- Step stop lever, so that the engine gear in the forward position, can move forward normally.
- The reverse handle must be in position to allow the engine to be put into reverse/forward gear.

Braking

- Release the accelerator completely and release the clutch to slow down the vehicle.
- Switch to first gear.
- When parking, please ensure that the front and rear brakes are used at the same time. If necessary, the downshift or the complete releasing of the clutch shall be performed to keep the engine from flameout.
- Emergency braking, negligent deceleration and excessive braking force can cause sideslip (sliding)
- Brake lightly when turning and slow down before turning.

Turn off the engine

- Release the accelerator completely
- Switch to neutral gear.

- Turn the key to the “” position.
- Lock the direction lock.

Emergency stop

Considering the safety and convenience of driving, but also in order to meet the requirements of design and safety, it is also for you, the user, the driver and the vehicle maintenance process may appear DANGER or throttle failure, use this switch to protect personal safety.

1. Improper maintenance or improper valve clearance adjustment can cause soil and dust to enter the intake system.

2. When removing the valve, soil is easy to enter and block the fuel system.

When the above-mentioned throttle loss occurs, you can stop using the front and rear braking and holding the clutch handle. Use these stop procedures before turning off the engine with the engine flameout switch. If the engine flameout switch is used, the ignition switch should also be located in the “” position and then stop.

Parking

- Switch to neutral and turn off the power key.
- Turn the Parking brake handle to the "ON Parking" position.



When the PC car is parked on the side of the road at night, the position light should be turned on.

Do not turn on the position light for a long time to avoid battery loss.

- If the vehicle is parked in a repair room or other building, ensure that there is good ventilation and no flames or sparks inside. These include service lights.



When the engine is running or just stopped, the muffler and exhaust pipe are very hot. To avoid fire or personal injury, do not let combustible materials such as grass or dry wood near the muffler and exhaust pipe.

- Lock the directional lock to prevent theft.

Catalyst

A catalytic converter is installed in the exhaust system of this car. The platinum and rhodium in the catalytic converter react with the carbon monoxide and convert the PC hydrocarbons into carbon dioxide and water to release into the atmosphere.

In order to use the catalytic converter correctly, the following warnings must be observed:

- Use only unleaded gasoline, no leaded gasoline. Leaded gasoline seriously shortens the service life of catalytic converters.

- Do not allow the vehicle to glide with the ignition switch off or the flameout switch off; If the battery power is insufficient, do not try to start the engine for a long time; Do not drag or allow the piston to move when the engine is not in neutral. Under these conditions, too much unburned oil and gas mixture will flow out of the engine into the exhaust system, causing it to accelerate and react with the catalytic converter and cause damage when the engine is heated, or reduce the catalytic performance when the engine is cooled.

 **NOTE**

Follow the following instructions to protect your motorcycle catalytic converter.

1. Only use unleaded gasoline. Even a small amount of lead will stain the precious metals in your catalytic converter and make the catalytic reaction converter ineffective.
- 2, do not add anti-rust oil or oil to the muffler, otherwise it will make the catalytic reaction conversion failure.

Fuel evaporation system

When the fuel evaporation system fails, please contact the Changjiang Service shop for repair. Do not modify the fuel evaporation system, which may result in non-compliance with the fuel evaporation emissions regulations. After disassembly and maintenance, check that the pipe connection should be good, and the pipe joint should be free of air

leakage, blockage and other phenomena; Hose without extrusion, rupture, damage and so on. The fuel vapor in the fuel tank is released into the carbon tank through the desorption pipe. When the engine stops working, the active carbon in the carbon tank absorbs the fuel vapor. When the engine is working, the fuel vapor in the carbon tank is released into the engine combustion chamber through the desorption pipe to participate in combustion, preventing the fuel vapor from directly discharging into the atmosphere and causing environmental pollution. At the same time, the adsorption tube also has the balance of the gas pressure in the fuel tank, when the gas pressure in the fuel tank is lower than the external atmospheric pressure, through the carbon tank air tube and adsorption tube to supplement the gas pressure in the fuel tank; Therefore, it is necessary to ensure that the pipelines are unobstructed, prevent blockage, extrusion and other phenomena, and ensure that the anti-tilt valve is installed correctly, otherwise it may cause damage to the fuel pump or fuel tank deformation, rupture, or damage to other components.

Safe driving

Safe driving skills

The following are notes for daily driving. Please read them carefully before driving to ensure safe and correct driving.

To be safe, it is highly recommended that you wear goggles and a helmet. You must know the traffic laws for safe motorcycle driving. You must also wear gloves and proper footwear, socks and other protective gear.

To prevent collision with vehicles, you must wear protective clothing when driving. Without protective clothing, you cannot guarantee your personal safety.

Before changing lanes, check the cars on your left, right, and behind you to make sure it's safe to cross. Don't just rely on the rear view mirror, you must judge the distance and speed of other vehicles, otherwise it is easy to crash.

When climbing steep slopes, use a lower gear to increase engine torque output so as not to overload the engine. When braking is used, front, rear, and side wheel braking are used simultaneously. If only one is used, sudden braking can cause the vehicle to skid (skid) and lose control.

When going down a long slope, release the throttle to control the speed, and use the front and rear auxiliary braking. When driving in wet terrain, try to use the throttle to control the speed, reduce the use of front and rear wheel braking force, throttle must also be controlled properly, to avoid letting the rear wheel accelerate too fast or slow down too fast cause the vehicle sideside.

Driving speed is stable, avoid unnecessary acceleration, not only can ensure important personal safety, but also can reduce fuel consumption, prolong the service life of the vehicle and reduce noise.

When driven on wet or soft roads, the motorbike's maneuverability will be reduced. Under these conditions, your entire driving movement must be coordinated and flexible, such as sudden acceleration, braking, or turning can cause loss of control.

Practice driving carefully in open areas, slow down and clamp the fuel tank with your knees to increase vehicle stability. Shifting to a lower gear gives you the necessary power when you're experiencing unwanted acceleration. When using low gear, the engine speed should not be too high to avoid damage to the engine.

Avoid unnecessary braid entangling the driver and vehicle.

Routine safety inspection

It is needed to check the following matters before driving every day to form this habit to ensure the safety and reliability of your vehicle. In case of finding any abnormalities, please read the adjustment chapters or contact your dealer for repair.



If you continue to drive, you may cause serious damage to the vehicle or have an accident.

Fuel: It should be added properly without leakage.

Engine oil: the oil level should be in the middle of the upper and lower scale lines of the oil observation window.

Tire: tire pressure (cold state)

Front wheel	Load: 243kg	Air pressure: 225kPa
Rear wheel	Load: 243kg	Air pressure: 225kPa

Drive chain: tightness level: 10mm-20mm. It is needed to add lubricating oil when it is dry.

Nuts, bolts, fasteners: Check the torques and tightness levels of control parts, suspension parts, shafts and all control parts.

Control: The action should be flexible and smooth, but the locking parts should not be loose. It cannot be entangled by the control cable.

Braking: In case the brake friction plate is worn, the minimum effective thickness should be greater than 1mm. The brake fluid cannot be leaked.

Accelerator: clearance: 2mm-3mm.

Clutch; clutch handle clearance: 2mm-3mm. The operation of the clutch handle should be flexible.

Coolant: The coolant cannot be leaked and the coolant should be kept between 1 / 3 and 1 / 2 volume.

Electrical installation: All lamps (headlamp, tail lamp/brake lamp, turn lamp, warning/signal indicator lamp) and horn shall be able to operate normally.

It is important to read all warning contents on the vehicle.

Special cautions on high speed driving

Braking: Braking is very important when driving at high speed. The braking force should not be too large. It is needed to check and make a proper adjustment to ensure proper braking performance.

Control: The looseness of controls may cause the vehicle to lose control. The inspection items should be performed, such as the direction handle should be flexible but not waggle randomly.

Tire: When driving at high speed, the key to safe driving is that the tire should be firm and in good condition. It is needed to check the air pressure comprehensively for guaranteeing the stable rotation.

Fuel: It is important to ensure sufficient fuel and smooth fuel supply when driving at high speed.

Engine oil: To avoid the fault of the engine and the out of control of the vehicle, it is needed to make sure that the oil level is between the upper and lower scale lines of the oil observation window and even as far as possible in the middle.

Coolant: To avoid engine overheating, it is needed to check that the coolant level is between 1/3 and 1/2 volume.

Electrical installation: It is needed to ensure that all headlamps, tail lamps/brake lights, turn lamps, horns, etc. operate normally.

Fasteners: It is needed to ensure all nuts and bolts are tight and all safety-related components are in good condition.



Motorcycles are not allowed on the highway unless you have the permission of the traffic authority and the relevant skills.

Maintenance and adjustment

Regular maintenance chart

■: It must be maintained by professional personnel designated by the Dealer.

*: The maintenance interval period is determined by the number of total mileage.

#: It is needed to shorten the maintenance period when driving in bad conditions (such as dust, humidity, mud, high-speed driving or frequent starting/flameout, etc.).

1. Regular inspection (engine-related terms)

Period Matter (engine)	Whichever comes first Every other	*The total mileage shows the number km x 1000						
		1	6	12	18	24	30	36
Air filter element - cleaning				•		•		•
Air valve clearance - inspection	42000km							
Accelerator system (clearance, flexible return) - inspection	1 year	•		•		•		•

Idle speed - inspection		•		•		•		•
Fuel leakage (fuel pipeline) - inspection	1 year	•		•		•		•
Fuel pipe damage - inspection	1 year	•		•		•		•
Fuel pipe installation - inspection	1 year	•		•		•		•
Throttle valve body - cleaning			•	•	•	•	•	•
Coolant level - inspection	1 year	•		•		•		•

Coolant leakage - inspection	1 year	•		•		•		•
Radiator, water pipe damage - inspection	1 year	•		•		•		•
Air intake system damage - inspection				•		•		•

2. Regular inspection (chassis-related terms)

Matter (chassis)	Period	Whichever comes first Every other	*The total mileage shows the number km x 1000						
			1	6	12	18	24	30	36
Clutch and drive chain									

Clutch control (clearance, engagement, disengagement) - inspection		•		•		•		•
Drive chain lubrication - inspection #	600km							
Drive chain tightness - inspection #	1000km							
The wearing of drive chain - inspection #				•		•		•
The wearing of the protective card of drive chain - inspection				•		•		•

Rim and tire								
Tire air pressure - inspection	1 year	•		•		•		•
Rim / tire damage - inspection				•		•		•
The wearing and the abnormal wearing of tire surface - inspection				•		•		•
Rim bearing damage - inspection	1 year			•		•		•
Pedal - lubrication		•		•		•		•
Chain wheel								

seat bearing - inspection				•		•		•
---------------------------	--	--	--	---	--	---	--	---

Period Matter (chassis)	Whichever comes first Every other	*The total mileage shows the number km x 1000						
		1	6	12	18	24	30	36
Braking system								
Braking fluid leakage - inspection	1 year	•	•	•	•	•	•	•
Braking fluid pipeline damage - inspection	1 year	•	•	•	•	•	•	•

The wearing of braking plate - inspection #			•	•	•	•	•	•
Braking fluid pipeline installation - inspection	1 year	•	•	•	•	•	•	•
Braking fluid level - inspection	6 months	•	•	•	•	•	•	•
Braking control (braking force, clearance, flexible	1 year	•	•	•	•	•	•	•

action) - inspection								
Braking lamp switch operation - inspection		•	•	•	•	•	•	•
Suspension								
Front fork/rear shock absorber (smooth cushioning) - inspection				•		•		•
Front fork/rear shock absorber oil leakage -	1 year			•		•		•

inspection								
------------	--	--	--	--	--	--	--	--

Period Matter (chassis)	Whichever comes first Every other	*The total mileage shows the number km x 1000						
		1	6	12	18	24	30	36
Operating system								
Steering clearance - inspection	1 year	•		•		•		•
Steering bearing - lubrication	2 year			•		•		•
Electric system								
Lighting and switch	1 year			•		•		•

operation - inspection								
Headlamp optical shaft - inspection	1 year			•		•		•
Engine flameout switch operation - inspection	1 year			•		•		•
Alarm system - inspection	1 year			•		•		•
Chassis								
chassis components - lubrication	1 year			•		•		•
Bolt, nut	1 year							

torque - inspection		•		•		•		•
Fuel evaporation system - inspection			•					

3、定期更换

3. Regular replacement

Period Replacement matter	Whichever comes first Every other	*The total mileage shows the number km x 1000				
		1	12	24	36	48
Air filter element #	2 years					
Engine oil #	Half a year	Every other 3000km (500km for the first time)				
Oil filter	Half a year	Every other 6000km				

Fuel pipe	4 years					•
Coolant	2 years				•	
Radiator, water pipe	2 years				•	
Braking fluid pipeline	4 years					•
Braking fluid (front/rear)	2 years			•		•
Rubber seal of the main pump	4 years					•
Sparking plug			•	•	•	•
Buffer block of chain wheel seat			•	•	•	•

Engine oil

To guarantee the normal operation of the engine, transmission mechanism and clutch and other moving parts, it is necessary to ensure that the oil level in the engine is between the upper and lower scale lines of the oil observation window. Besides, it is needed to perform the inspection and replacement according to the regular maintenance chart. In the process of lubrication for a long time, it will not only produce dirt and metal impurities but also consume itself.

DANGER

If insufficient engine oil, poor oil quality, oil is too dirty and other conditions of driving vehicles, will accelerate engine wear and it cause engine or transmission mechanism sintering, accidents and personal injury.

Level inspection of oil volume

- After the oil is changed, it is needed to start the engine and operate at idle speed for a few minutes to fill the oil filter with oil. Later, it is time to turn off the engine and wait a few minutes until the oil deposits.

WARNING

Running the engine at a high speed before the oil reaches every part can cause the engine

moving parts to sinter.

- In case the vehicle is just in use, it is necessary to wait a few minutes to drain the engine oil.
- It is needed to check the engine oil level through the oil observation window. In case of parking the vehicle on the level ground, the oil level must be between the upper and lower scale lines of the oil observation window.
 - In case the oil level is too high, it is needed to drain the excess oil.
 - In case the oil level is too low, it is needed to add the same type of oil to the middle of the upper and lower scale lines of the oil observation window.

Change engine oil and oil filter

- Park the car on the level ground.
- Operate the engine first and then stop the engine when it is hot.
- Place the oil pan in the oil draining position.
- Remove the oil draining bolt.
- Drain the oil thoroughly.



DANGER

Oil is a toxic substance and should be stored in a safe place after use.

- Remove the oil filter and replace it with a new one.



NOTE

If you do not have the professional tool, please contact your dealer.

- Apply a thin oil film on the sealing ring and tighten it according to the specified torque.
- Install the oil draining bolt with a new washer.



NOTE

Replace all gaskets with new ones

- Use the high-quality oil listed below and add it to the middle of the upper and lower scale lines of the oil observation window.
- Start the engine.
- Check the oil volume level and oil leakage.

Torque tightening

Oil draining bolt: 30N·m Oil filter: 17.2N·m

Recommended oil:

Type: SJ level JASO MA2 certified oil Viscosity: ELF Company 10W-40.

Oil volume of engine:

When the oil filter is not changed: 2.0L

When the oil filter is changed: 2.2L

When the engine oil is completely drained: 2.6L is required to use APISH level oil and above. The first choice is JASO MA2 certified oil and the second is JASO Ma certified oil.

Although 10W-40 is one of the recommended oils to meet most ambient temperature conditions by us. It is needed to change the viscosity of the oil when the ambient temperature condition changes in your driving area. Please make a choice according to the table below.

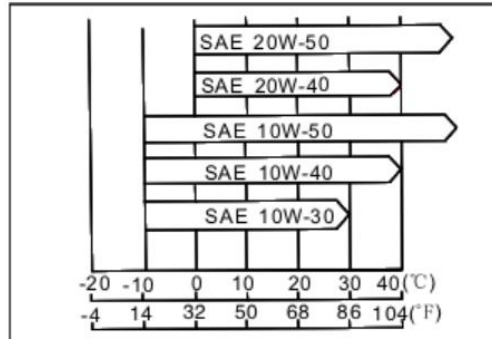

Cooling system

Radiator and cooling fan

It is important to check whether the radiating fin is deformed or blocked by sediment and clean the radiator with tap water.



Keep your hands and clothes away from the fan when it is rotating.



When a high-pressure water gun is used to clean a vehicle, the radiator plate may be damaged and the heat dissipation efficiency of the radiator may be reduced.

Installing accessories in front of the radiator or behind the fan may block or alter airflow through the radiator, causing the engine to overheat and damage the engine.

Radiator pipeline

Before daily driving, it is important to check whether the radiator pipeline is leaked, cracked, aged and rusted and whether the joint is leaked or loose, etc. Besides, it is needed to regularly perform the inspection according to the maintenance chart.

Coolant

The coolant absorbs the heat from the engine and is discharged into the atmosphere through the radiator. In case the coolant level is too low, the engine will overheat and can seriously damage the engine. It is significant to check the coolant level before daily driving and check it regularly according to the maintenance chart. In case the coolant level is too low, the coolant should be added according to the maintenance chart.



Rusting and corroding residues in engines and radiators must be treated according to regulations. The chemicals in them are harmful to human health.

Distilled water added (if coolant amount is low) to the cooling system, must be used with antifreeze ratio.

 **WARNING**

If tap water is added to the cooling system, scale will accumulate in the cooling water pipeline, and seriously affect the cooling system.

If the ambient temperature is below zero, add antifreeze to the coolant to ensure that no ice will occur in the cooling system. It also inhibits rust and corrosion of the engine, radiator and cooling water pipe.

Antifreeze used in cooling systems (distilled water, glycol, and chemical inhibitors to prevent oxidative corrosion of aluminum, such as engines and radiators). The mixing ratio of coolant is prepared according to the cold degree of ambient temperature.

 **WARNING**

The bottled antifreeze on the market has added antirust and corrosion agents. When diluted, it loses its ability to resist rust and rot. The dilution concentration of antifreeze must be consistent with the manufacturer's instructions.



NOTE

When coolant is added to the cooling system, it is green in color and contains glycol. When the ambient temperature is -35°C , the coolant ratio concentration is 50%.

Level inspection of coolant

- Keep the longitudinal plane of the car body perpendicular to the horizontal ground.
- Check whether the coolant level is between $1/3$ and $1/2$ volume



NOTE

Check coolant level as engine cools (ambient temperature).

- In case the coolant is less than $1/3$, the coolant should be added to $1/2$ volume.

Add coolant

- Open the auxiliary water tank cover and add coolant to $1/2$ volume.
- Close the auxiliary water tank cover.



NOTE

Distilled water can be added to the secondary tank in case of emergency, however, the concentration of antifreeze mixture must be adjusted as soon as possible.

WARNING

If the coolant needs to be replenished frequently, or the coolant in the sub-tank is often sucked dry, the cooling system may leak, contact your dealer to check the cooling system.

Replacement coolant

Contact your dealer to replace the coolant.

Spark plug

The replacement of spark plugs must be in accordance with the periodic maintenance chart. Removing the spark plug must be done by your dealer. Spark plug type: CR8EI.

Spark plug clearance: 0.7mm~0.9mm。

Fastening torque: 15N·m

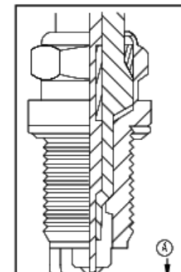

Intake and exhaust system

The gas emission monitoring system is monitored by an oxygen sensor. An oxygen sensor is installed on the exhaust pipe, which monitors how thoroughly the exhaust gas is burned and converts the detected oxygen content in the

A Spark plug clearance

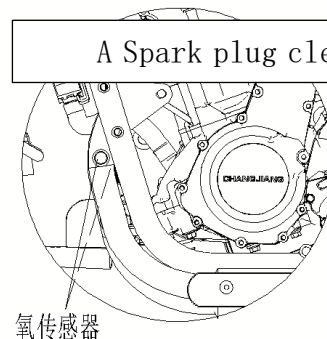

exhaust gas into an electrical signal to be transmitted to the ECU. When the ECU determines that the exhaust combustion is not complete, the ECU redetermines the injection volume of the injector according to the throttle position sensor's throttle opening signal and the intake temperature sensor's intake temperature signal, so that the oil and gas mixing ratio can be effectively adjusted, and finally ensure the thorough combustion of oil and gas.

Intake valve

An intake valve is a valve that controls the engine's intake from the air filter and prevents the gas from flowing back into the cylinder. Check according to regular maintenance chart. When the engine idle instability, engine power reduction, or abnormal engine noise, you can check the intake valve.

The disassembly and inspection of the intake valve must be done by your dealer.

Valve clearance

Valves and valve seats wear out during use and need to be adjusted after a period of use.



If the valve, valve seat tappet wear in the process of use after the valve clearance is not adjusted, resulting in the valve is not tight or no clearance, or cause engine performance decline, or engine idle abnormal sound, and can seriously damage the engine. The clearance of each valve must be specified, checked and adjusted according to the periodic maintenance chart. Checking and adjusting the valve clearance must be done by your dealer.

Air cleaner

Air filter clogging will reduce engine intake, increase fuel concentration, reduce engine efficiency and cause spark plugs to drown.

The filter element of the air filter must be cleaned according to the provisions of the regular maintenance chart. When driving in dusty, wet and muddy conditions, the air filter element must be maintained by your dealer more frequently than the recommended regular maintenance.

Throttle control system

Check the clearance of PC in throttle hand according to the regular maintenance chart and adjust if necessary.

Throttle hand control PC

Throttle hand PC control to throttle body. If the throttle hand PC clearance is too large, resulting in uncoordinated throttle action, that the throttle wire cable is too long, resulting in slow throttle response, especially at low engine speed. When the hand PC to the maximum, can also cause the throttle is not fully open; If the throttle hand PC clearance is too small, the throttle wire cable control is tight, and the idle speed is high or unstable.

CHECK

- Check the PC clearance of the throttle hand, and the PC rotation of the throttle hand should be flexible.
- If the throttle hand PC clearance is not appropriate to adjust

Adjustment

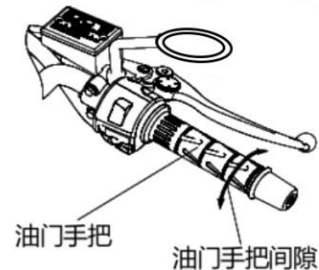

油门手把间隙：2mm~3mm

- Loosen the lock nut of the fuel door cable on the right hand PC switch and turn the pump
Adjust the nut of the throttle cable to make the throttle hand PC clearance suitable.
- Adjust the throttle cable gap until the throttle hand PC is fully back.
- Lock nuts should be tight.
- Loosen the return oil lock tightening nut and turn the return throttle adjusting nut until the throttle hand is PC
The clearance is 2mm to 3mm.
- Lock nuts should be tight.



Improper throttle adjustment and wrong cable running can damage the cable and lead to unsafe driving

Idle speed

The idling speed of this vehicle has been adjusted before delivery. The user cannot adjust the idling speed of this vehicle, otherwise the vehicle performance will be affected. When a part that affects idling needs to be replaced, you must contact your dealer to replace it and recalibrate the ECUs with a fault diagnosis device.



Improper idle speed adjustment will
cause unsafe driving.

Idle speed: 1400r/min±50r/min

Throttle body

The throttle limit screw on the throttle body has been precisely set and cannot be adjusted. Check whether the idling speed of the vehicle is stable. If the idling speed is not stable, please appoint the professional service personnel of the maintenance unit to check and deal with it.

Clutch

During prolonged use the clutch friction plate will wear and the clutch cable will stretch, so the clutch handling performance must be checked before daily driving, and the provisions of the periodic maintenance chart must be followed.



To avoid burns, do not touch the hot engine and exhaust pipe while
adjusting the clutch.

- Check the handling performance of the clutch handle, and the cable should be flexible.

If the clutch operation is abnormal, contact your dealer to check.

- Check the clearance of the clutch handle.

Clearance: 2mm ~ 3mm if the clearance is not correct, adjust the clutch handle clearance.

Adjustment

- Loosen the lock nut and turn the adjusting nut to make the clutch handle clearance fit.

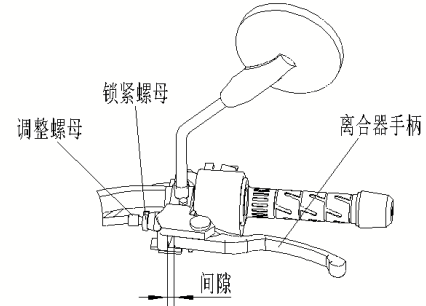

DANGER

Make sure that the head of the clutch cable is properly installed and the lock nut is fastened. Otherwise, the cable may slip out and cause the clutch to not disengage, resulting in unsafe driving.

- If the clutch cable handle end is adjusted to the limit position and can not meet the requirements of the handle clearance, then adjust the cable and engine end adjustment nut.

NOTE

After adjustment, start the engine, check the clutch should work smoothly and return flexibly.

Drive chain

The tightness and lubrication of the drive chain must be checked before daily driving, and the safety matters stipulated by regular maintenance must be observed to prevent excessive wear of the drive chain. If the drive chain too much wear, or adjustment is not appropriate, cause the chain is too loose or too tight can cause the chain to fall off or produce resistance.



Dragging or falling off the chain can slow down the engine or lock the rear wheel, potentially seriously damaging the vehicle and causing loss of control.

Chain tightness check

- Chain tightness check
- Turn the rear wheel to check if the chain is too tight, and press the middle of the chain to measure the distance between the upward and downward tightness.
- If the chain is too loose or too tight, adjust to the standard value.

Standard value: 10mm-20mm

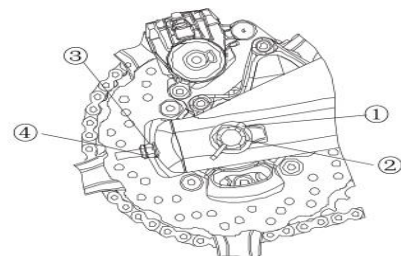
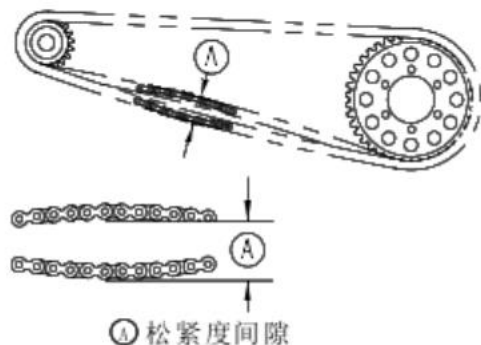

① 开口销 ② 链轴锁紧螺母
③ 链条调整螺母 ④ 链条锁紧螺母

Adjustment

- Loosen the chain regulator lock nut.
- Remove the cotter pin of the right axle lock nut and loosen the rear axle lock nut.
- If the chain is too loose, turn the left and right adjusting nut clockwise, and the left and right adjusting amount is equal.
- If the chain is too tight, turn the left and right adjustment nut counterclockwise, and the left and right adjustment amount is equal.

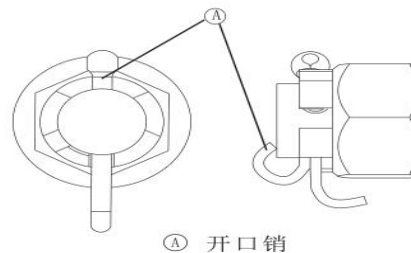

- Turn the adjusting nut until the chain tightness is adjusted properly.
- Ensure that the left and right displacement of the rear axle on the rear fork is consistent.

 **NOTE**

Rear axle mounted on rear fork left and right scale line consistent.

 **DANGER**

When the rear wheel is not properly installed, it will cause abnormal wear and tear and unsafe driving.

- Lock the left and right chain adjuster lock nuts.
- Lock the rear axle nut according to the specified torque.
- Rear axle nut torque: 120N·m
- Rotate the rear wheel to measure the tightness of the chain again and adjust if necessary.
- Install new cotter pins and separate PC cotter pins.

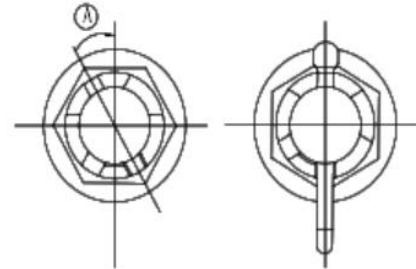

 顺时针旋转

 **NOTE**

When inserting a cotter pin, if the nut slot is not aligned with the pin hole of the shaft, turn the nut clockwise to the next Angle.

The Angle between the cotter pin and the vertical horizontal ground must be within 30°. When the nut slot is not aligned with the nearest axle hole, adjust the nut Angle.

 **DANGER**

If the rear axle nut is not locked according to the specified torque or the cotter pin is not installed, it may cause unsafe driving.

Abrasion inspection

- The chain is tensioned, or a 10kg mass is hung from the chain.
- Measure the length between the center of the 20 links after being stretched.
- If stretched beyond the standard limit of use must be replaced with a new. Maintenance limit of the length between the center of the 20 links of the drive chain: 323mm

 **DANGER**

For your safety, use a standard chain. When the chain is stretched, the PC chain can not be cut short and then installed back on the car for use. Must contact the dealer for a new chain.

- Rotate the rear wheel to check the wear of the chain roller and the loosening of the chain link node.
- Check sprocket tooth surface wear and damage.



NOTE

See the following sprocket tooth surface wear legend.

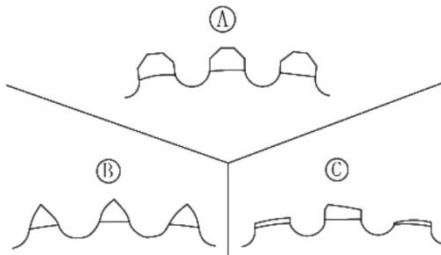

Ⓐ 标准齿型 Ⓑ 磨损的齿型 Ⓒ 损坏的齿型

- If this happens, contact your dealer for a new chain or sprocket.

lubrication

The sprocket and chain must also be lubricated when driving on rainy or wet roads, or when the sprocket and chain appear dry. The use of high viscosity oil such as: recommended SAE90 than low viscosity oil in the sprocket and chain store longer, can reduce the frequency of lubrication.

- Lubricating oil is added to both sides of the chain roller to facilitate the penetration of lubricating oil into the roller.
- If the chain is particularly dry, clean the chain before lubricating it.

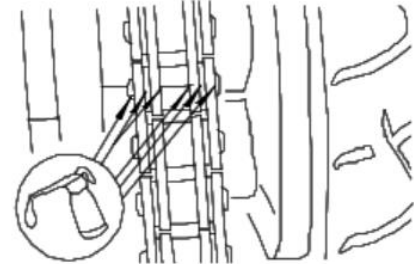

Brake

Check for brake wear

Check the brake for wear, check the brake calipers on the front, rear and side brake discs. If the thickness of the brake friction plate is less than 1mm, replace the brake friction plate with a new one. The replacement of the brake friction plate must be completed by your dealer.

Brake oil cup

Check the horizontal fluid position in the front and rear brake oil cups and replace the brake fluid according to the periodic maintenance chart. Brake fluid must be replaced when it becomes contaminated or seeps into water.

Brake fluid requirement

Use only the DOT4 brake fluid type marked on the oil cup.



Brake fluid should not splash onto the surface of plastic parts or coated parts. Do not leave the brake fluid exposed to air for a long time or unsealed for a long time.

Check for brake fluid leakage.

Brake fluid level check



Check whether the brake fluid level in the front and rear brake oil cups is between the upper and lower scales.

① Front brake oil cup cover ② upper limit scale ③ lower limit scale ④ front brake oil cup

- If the brake fluid level is lower than the lower limit scale line, check whether the brake fluid pipeline leakage and add brake fluid to the upper limit scale line of the oil cup. The upper limit scale of the front brake oil cup is on the inside, which can be seen only when the oil cup cover is opened.

 **DANGER**

Do not mix different brands of brake fluid. When the type and brand of brake fluid added to the brake oil cup cannot be determined, the brake fluid must be added again after the brake fluid is completely drained.

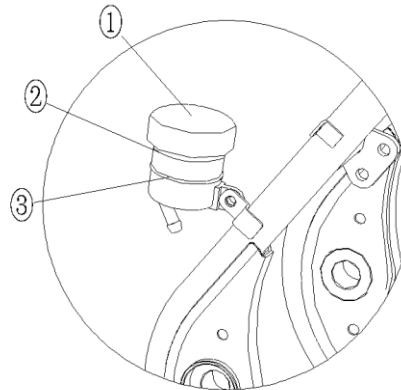

- ①Rear brake oil cup ②upper limit scale line ③lower limit scale line

Brake fluid replacement

Brake fluid replacement must be done by contacting your dealer.

Front, rear and side brake disc and brake friction disc will be worn in the process of long-term use, and must be checked or replaced according to maintenance regulations.



DANGER

If the brake handle and brake pedal feel soft in operation, the brake line may contain insufficient air or brake fluid. Do not drive the car when it is in DANGER. Contact your dealer immediately to check the brakes.

Checking

- The PC ignition switch is set in the "○" position.
- The brake light must be lit when the front brake is used. Dealer checks the front brake switch.
- Check the rear brake switch. When the rear brake pedal is depressed, the brake light must also be lit.
- If the brake light does not light, check the front and rear brake switch cable connectors.

Rear brake pedal travel: 10mm。

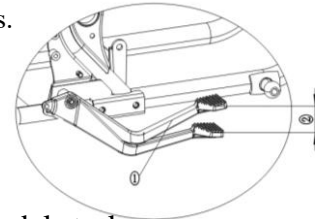

- ①Rear brake pedal ②rear brake pedal stroke

Front fork

Front fork handling and leakage of damping oil must be checked according to periodic maintenance chart.

Check the front fork

- Hold the front brake handle and compress the front fork several times to check that it works smoothly.
- Observe whether there is leakage of shock absorbing oil, and whether there are scratches and friction abnormal sound in the working part of the front fork tube.
- You must contact your dealer if any problems are found with the former shock absorber.

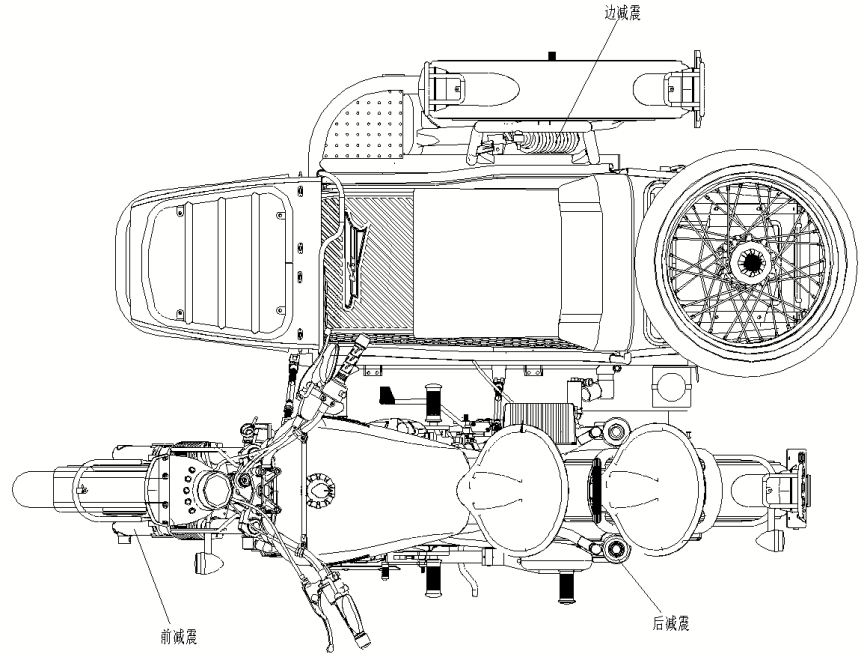

Rear/side shock absorption

Rear/side shock absorbers must be inspected for handling and leakage of shock oil as specified in the periodic maintenance chart.

Check the shock absorber

- Compression cushion after several checks/side shock absorber work smoothly.
- Observe the shock absorber for leakage.
- If any problems are found with the shock absorber, you must contact your dealer.

Rear shock absorber spring/side shock absorber spring preload adjustment

There are five gears for preloading load adjustment.

Gear position	1	2	3	4	5
Spring force	Spring force increase →				



This component contains high-pressure nitrogen. Incorrect operation may cause explosion. Read the instructions. Do not PC it into the fire, open or open.

Tire

Load and tire pressure

Improper tire pressure or exceeding tire load limits may affect handling and vehicle performance and cause loss of control. We recommend a maximum load of 225 kg, including driver, luggage and accessories.

- Remove valve nozzle cover.
- Pls use a barometer to measure tire pressure.
- Make sure the valve nozzle cover is installed reliably.

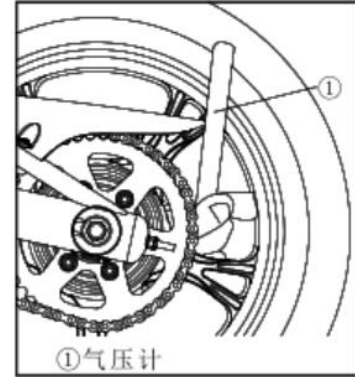

Tire pressure (cold)

Front wheel	200Kpa
Rear wheel	225Kpa
Side wheel	210Kpa

Tire worn and damaged

When the tire surface wear exceeds the use limit, it will be punctured and malfunction. Generally 90% of tire failures occur in the last 10% of tire life. So the tire surface wear to the smooth surface when continued use will cause unsafe factors.

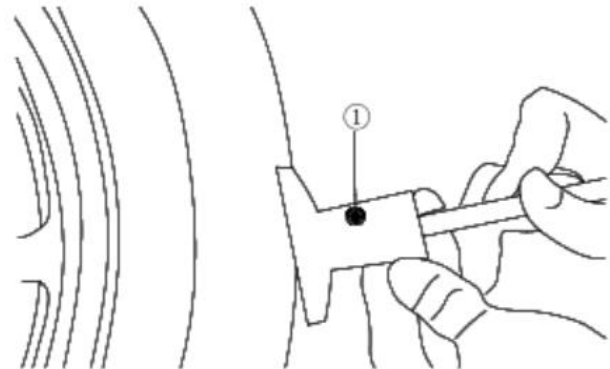

①测量轮胎面深度尺

Measure the depth of the tire tread according to the regular maintenance drawing, and replace the new tire when the wear reaches the minimum service limit.

Minimum service depth of tire surface

Front wheel	0.8mm~1mm
Rear wheel	0.8mm~1mm
Side wheel	0.8mm~1mm

- Visual inspection tire surface cracks and notches, serious damage replacement of a new tire. For example, the local expansion of the tire indicates that the tire is damaged.
- Remove sand, stones and other foreign bodies stuck in the tire surface.

 NOTE
Most countries have their own minimum tyre tread depth and their rules must be followed. Check wheel balance when installing new rims and tires.

 DANGER
To ensure the safety and stability of operation, only our recommended tires and air pressure are used. The speed of a punctured tire should not exceed 100km/h within 24 hours after repair, and

should not exceed 109km/h at any subsequent time.

When driving on the highway, ensure that the maximum speed is below the legal limit.

Tyre specification

CJ700B-A/CJ700B-2		CJ700B-6	
Front wheel	4.0-19	Front wheel	120/80-17
Rear wheel	4.0-19	Rear wheel	120/80-17
Side wheel	4.0-19	Side wheel	120/80-17

 **DANGER**

Front, rear and side wheels use the same supplier's

 **DANGER**

The surface of the new tire is smooth and can cause loss of control and injury. After 160km of run-in period, the tire surface can form normal friction surface. Avoid sudden, extreme braking, extreme acceleration and sharp turns during run-in.

Battery

The car is equipped with maintenance-free battery, so it is not necessary to check the battery electrolyte level or add distilled water. Once the PC electrolyte is poured into the battery, the seal does not have to be removed. However, in order to maximize the battery life, you must properly charge the battery to ensure that the starter motor needs the power. The motorcycle charging system automatically charges the battery when the motorcycle is in regular use. If you use a motorcycle only occasionally or for a short time, the battery power may be insufficient. The battery discharges itself. The self-discharge rate varies depending on the battery type and ambient temperature. When the ambient temperature rises, for example, when the ambient temperature rises 15 ° C, the self-discharge rate doubles.

In very cold weather, improper battery charging, easy to cause the electrolyte icing, icing can cause the battery rupture and metal plate deformation, to fully charge the battery can improve the anti-freezing ability.

Battery sulfation A common battery failure is sulfation. When the battery loses power for a long time, the electrolyte can be sulfated. Sulfation is a chemical reaction inside the battery that produces an abnormal product. If the battery occurs sulfuric acid salination, continue to let the battery discharge, the battery plate cause permanent damage, and cause the battery can not be charged. When such a fault occurs on the battery, only a new battery can be replaced.

Battery maintenance

Ensure that the battery is fully charged; otherwise, the battery will be damaged. If your vehicle is rarely driven, check the battery voltage weekly with a voltmeter. If the battery voltage is below 12.8V, you must use a charger to charge the battery (contact your dealer to check). If you do not use your vehicle for more than two weeks, you must use a charger to charge the battery. Do not use the automatic fast charger to charge the battery, otherwise it may cause battery overload and damage the battery.

Battery charging

- Remove the battery from the car.
- Connect the charger wire and ensure that the charging current is 1/10A of the battery capacity. For example, to charge the battery with the capacity of 20Ah, its charging current is 2 amps.
- When you load the PC battery back to the car, make sure the battery is fully charged.

WARNING

Do not disassemble the battery seal; otherwise, the battery will be damaged. Do not install ordinary battery on this car, otherwise it may lead to electrical system working abnormal.

Before charging a maintenance-free battery, read the instructions on the battery.

Remove battery(CJ700B-A/CJ700B-2)

- Remove the battery case strap bolt and take off the battery case cover.
- Disassemble the positive and negative cables from the battery and remove the battery.
- Use carbonated water and water to clean battery terminals, positive and negative cable terminals must also be cleaned.



Remove Battery (CJ700B-6)

- Remove the side cover on the right side of the main seat first.
- Pull the rubber band of the battery box down to remove the fixing ring from the hook on the battery box.
- Disassemble the positive and negative cables from the battery and take out the battery.
- Use carbonated water and water to clean battery terminals, positive and negative cable terminals must also be cleaned.



側蓋

橡膠箍帶

Battery installation

- Put the PC battery into the battery box.
- Connect the positive terminal of the battery, and then connect the negative terminal of the battery.



When a battery is installed, the connection sequence of the positive and negative terminals is the opposite of that when the battery is removed.



WARNING

Negative and positive connection can seriously damage the electrical system.

- After the positive and negative terminals are connected, apply conductive grease to the terminals and terminals to prevent corrosion.
- Cover the positive and negative electrode jackets.
- Reassemble the disassembled parts.

Light signal system

The headlamp far/near light can be changed by the right hand PC switch.

The left turn signal is a separate light source, while the right turn signal is integrated with the position light

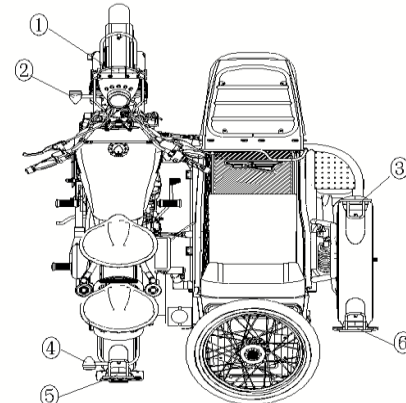

- ① 远光灯/近光灯/位置灯
- ② 前左转向灯
- ③: 前右转向灯/位置灯
- ④ 后左转向灯
- ⑤: 刹车灯/位置灯
- ⑥ 后右转向灯/位置灯

Together.

The brake light is integrated with the left rear position light.

Headlamp light adjustment (CJ700B-A/CJ700B-2)

The height of the low/high beam is adjustable.

- Loosen the fastening bolts on both sides of the headlamp.
- Turn the lamp holder until the beam fits.
- Tighten the bolts on both sides of the headlamp.

Headlamp light adjustment (CJ700B-6)

The height of the low/high beam is adjustable.

- Loosen the lower side fastening nut of the headlamp.
- Turn the lamp holder until the beam fits.
- Tighten the headlamp fastening nut.

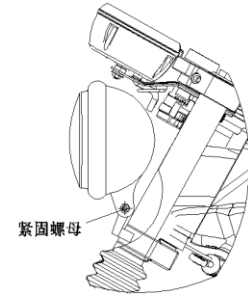
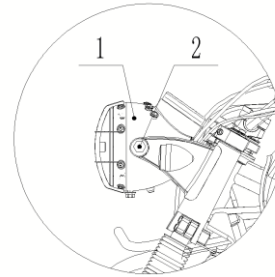

The front and rear wheels hit the ground and the driver sits on the vehicle to adjust the far/near optical axis. Adjust the far/near optical axis to suit local regulations.

Cleaning car

General preventive measures

Keep the appearance of your vehicle clean and ensure that the vehicle is driven under optimal performance, which will extend the service life of the vehicle. Protect your vehicle with high-quality, breathable motorcycle overalls.

- Ensure engine and exhaust pipe cooling before cleaning.
- Avoid using stain remover on seals, brake pads and tires.
- Manual cleaning of vehicles.
- Avoid using chemicals, solutions, detergents and household cleaners such as ammonia to clean your vehicle.
- Gasoline, brake fluid and coolant will damage the surface of the paint. If it sticks to the surface of the paint, it should be cleaned immediately with water.
- Avoid using metal brushes, steel wire cleaning balls or other objects that are too rough to wipe the vehicle.
- Special care should be taken when cleaning windshields, lampshades and all plastic parts that scratch easily.
- Avoid using water cannons, or water may run into seals and appliances and damage your vehicle.
- Avoid spraying water into waterproof areas such as air intakes, fuel systems, electrical appliances, muffler exhaust ports and fuel tank locks.

Washing the car

- Rinse the dirt off the motorcycle with cold water.
- Moderately mix a bucket of cleaning agent (special for cleaning motorcycles or cars) with a bucket of clean water. Use a soft cloth or sponge to clean your vehicle. If needed, mix a bucket of light oil remover to clean oil or grease dirt.
- After cleaning, rinse the car with clean water (cleaning agent residue can damage your motorcycle parts).
- Use a soft cloth to dry your motorcycle and check your motorcycle for scratches.
- Start the engine and let it run at idle for a few minutes. The heat generated by the engine helps dry the vehicle in wet environmental areas.
- Drive your vehicle carefully at low speeds and apply the brakes several times. This helps to dry the brake and return it to normal operating performance.
- Lubricate the drive chain to prevent rust.

WARNING

Simply wash your vehicle with cold water immediately after driving on a road with high salt spray or near the sea. Do not wash with warm water that accelerates the chemical reaction of salt. After drying, the non-coated surface of the metal is protected by anti-rust and corrosion oil. When driving on a rainy day or after washing your car, there may be water mist on the inner surface of the headlamp hood. Start the engine and turn on the headlamp to remove water vapor.

Decorative surface

After washing the car, polish the surface of the metal and plastic parts with a motorcycle or car wax. Wax must be applied every three months or if necessary to avoid satin or dull finish on the surface of the coating. Ensure that the wax used is a non-abrasive product and that the instructions are followed.

Windshields and other plastic parts

After cleaning, use a soft cloth to gently dry the surface of the plastic parts. When drying, apply the prescribed cleaning or glazing procedure to windshields, lampshades and other non-coated plastic parts.



If plastic parts come into contact with chemical substances or household cleaning products can occur aging and rupture, such as: gasoline, brake fluid, window cleaning fluid, thread fastening glue or other chemicals. If plastic parts come into contact with any reactive chemicals, wash them off immediately with water and check for damage. Avoid using abrasive flakes or brushes to clean the surface of plastic parts, as they will damage the surface shine of plastic parts.

Chrome and aluminum

Chromium alloy and non-coated aluminum parts will be oxidized by air, the surface becomes dull and lustrous, must be cleaned with descaling agent, and the use of polish. Aluminum coated wheels and non - coated wheels must be cleaned with special detergent.

Leather products, vinyl products and rubber products

If your motorcycle has leather products, you must use a special cleaning agent for leather products. Cleaning leather products with detergent and water will damage them and shorten their lifespan.

When washing the car, the surface of vinyl products must be treated separately.

Tires and other rubber parts must use special rubber protectants to extend their service life.



When handling tyres, special care must be taken to understand that the rubber protectant applied to the tyre will not affect the function of the tyre. Improper handling may affect the adhesion of the tire to the ground, causing the driver to lose control.

Store

Preparation before storage

- Clean the vehicle thoroughly.
- Let the engine work for about 5 minutes to let the oil get hot, stop the engine and drain the oil from the engine.



Motorcycle oil is toxic, used oil should be thoroughly disposed of. Keep the PC out of the reach of children. If it sticks to your skin, do something about it immediately.

- Put on new engine oil.
- Drain the fuel in the fuel tank (NOTE: when the fuel pump can't pump the fuel quickly, remove the fuel pump connector, use the pipe to drain the fuel in the fuel tank, otherwise damage the fuel pump).



Gasoline is very easy to burn and explode under certain conditions, so it must be operated before the PC power key set in the "  " position, can not smoke, determine the area is well ventilated, no flame or spark, including the use of working lights. Gasoline is toxic substances, should properly handle gasoline, contact with your skin immediately do the corresponding treatment, PC it stored in the place where children can't reach.

- Allow the engine to operate at idle and drain fuel from the fuel system until the engine automatically stalls (NOTE: Remove fuel pump connector or damage the fuel pump. If the motorcycle is stored for a long time, the fuel will deteriorate and block the fuel system).
- The motorcycle storage period, approximately reduce the tire standard air pressure by 20%.
- Use wooden boards to firmly set up the front, back and side wheel to prevent the motorcycle from touching the ground damp.
- Spray oil film on uncoated metal surface to prevent rust, and avoid spraying oil on rubber parts or brakes.
- Lubricate the drive chain and all cables.
- Remove the battery, PC it stored in a cool, ventilated place. The storage battery must be charged according to the periodic maintenance chart, to keep the battery sufficient power.
- Muffler exhaust is wrapped with a plastic bag to prevent moist air from entering.
- Cover the motorcycle overalls to prevent dust.

Remove the motorcycle from storage

- Remove the plastic bag from the muffler vent.
- Install the battery, and charge the battery first if necessary.
- Fill up the fuel.
- Review routine safety checks.
- Lubricate the pivot.

Read all warning messages on your motorcycle carefully and obey them before driving for the first time. See the object for details and corresponding positions on the motorcycle. If the Parameter in the instruction manual is inconsistent with the content of the WARNING label on the car, the content of the WARNING label on the car shall prevail.

Electronic spray system fault code

Overview of self-diagnosis

The electronic control unit ECU constantly monitors the sensor, actuator, related circuit, fault indicator light and battery voltage, and even the electronic control unit itself, and the sensor output signal, actuator drive signal and internal signal (such as closed-loop control, coolant temperature, idle speed control and battery voltage control) for reliability detection. Once a link is found to be faulty, or a signal value is not trusted, the electronic control unit immediately sets a fault information record in the RAM fault memory. Fault information records are stored in the form of fault codes and displayed in the sequence in which faults occur. Faults are classified into Current faults and Historical faults. During maintenance, the fault parts can be found quickly through the diagnostic instrument and fault indicator light to improve the maintenance efficiency and quality.

Fault light diagnosis process

When the EFI system and ignition system have problems, the fault light flashes.

Fault light strategy

- In the process of engine operation, when the system diagnoses the fault of a part, the fault light will be lit, and the fault light will keep flashing at a frequency of 2Hz. If the fault has been repaired but

the fault code has not been cleared by the fault diagnosis instrument, the fault light will continue to blink at a frequency of 2Hz when the ignition switch is turned on again for the first time after extinguishing, and the fault light will be extinguished after starting the engine. When the engine is powered on for the second time, the fault light is steady on until the fault light is extinguished after starting the engine. In this case, it is necessary to use a special fault diagnosis instrument to clear the fault code, so that the fault light can return to normal state when the next power on. If the fault code has been cleared by the fault diagnosis instrument at the same time, the fault light should be on for 4S and then off, or the engine should be started before the fault light is off.

No	Pcode	说明 (UAES)	Decription(UAES)
1	P0030	上游 1 缸氧传感器加热控制电路开路	O2 Sensor 1 Heater Contr. Circ. High
2	P0031	上游 1 缸氧传感器加热控制电路电压过低	O2 Sensor 1 Heater Contr. Circ. Low
3	P0032	上游 1 缸氧传感器加热控制电路电压过高	O2 Sensor 1 Heater Contr. Circ. Open
4	P0036	上游 2 缸氧传感器加热控制电路开路	O2 Sensor 2 Heater Contr. Circ. High
5	P0037	上游 2 缸氧传感器加热控制电路电压过低	O2 Sensor 2 Heater Contr. Circ. Low

6	P0038	上游 2 缸氧传感器加热控制电路电压过高	O2 Sensor 2 Heater Contr. Circ. Open
7	P0107	进气压力传感器对地短路	Manifold Abs.Pressure or Bar.Pressure Low Input
No	Pcode	说明 (UAES)	Decription(UAES)
8	P0108	进气压力传感器对电源短路	Manifold Abs.Pressure or Bar.Pressure High Input
9	P0112	进气温度传感器信号电压过低	Intake Air Temp.Circ. Low Input
10	P0113	进气温度传感器信号电压过高	Intake Air Temp.Circ. High Input
11	P0117	发动机冷却液温度传感器电路电压过低	Engine Coolant Temp.Circ. Low Input
12	P0118	发动机冷却液温度传感器电路电压过高	Engine Coolant Temp.Circ. High Input
13	P0122	节气门位置传感器电路电压超低限值	Throttle Pos.Sensor Circ. Low Input
14	P0123	节气门位置传感器电路电压超高限值	Throttle Pos.Sensor Circ. High Input
15	P0130	上游 1 缸氧传感器信号不合理	O2 Sensor Circ.,Bank1-Sensor1 Malfunction
16	P0131	上游 1 缸氧传感器信号过低	O2 Sensor Circ.,Bank1-Sensor1 low Voltage
17	P0132	上游 1 缸氧传感器信号电路电压过高	O2 Sensor Circ.,Bank1-Sensor1 High Voltage
18	P0134	上游 1 缸氧传感器电路信号故障	O2 Sensor Circ.,Bank1-Sensor1 No Activity Detected
19	P0136	上游 2 缸氧传感器信号不合理	O2 Sensor Circ.,Bank1-Sensor2 Malfunction
20	P0137	上游 2 缸氧传感器信号过低	O2 Sensor Circ.,Bank1-Sensor2 low Voltage
21	P0138	上游 2 缸氧传感器信号电路电压过高	O2 Sensor Circ.,Bank1-Sensor2 High Voltage
22	P0140	上游 2 缸氧传感器电路信号故障	O2 Sensor Circ.,Bank1-Sensor2 No Activity Detected

23	P0201	1 缸喷油器控制电路开路	Cylinder 1- Injector Circuit
No	Pcode	说明 (UAES)	Decription(UAES)
24	P0261	1 缸喷油器控制电路对地短路	Cylinder 1- Injector Circuit Low
25	P0262	1 缸喷油器控制电路对电源短路	Cylinder 1- Injector Circuit High
26	P0202	2 缸喷油器控制电路开路	Cylinder 2- Injector Circuit
27	P0264	2 缸喷油器控制电路对地短路	Cylinder 2- Injector Circuit Low
28	P0265	2 缸喷油器控制电路对电源短路	Cylinder 2- Injector Circuit High
29	P0321	转速参考点故障	Ign./Distributor Eng.Speed Inp.Circ. Range/Performance
30	P0322	无转速传感器脉冲信号(开路或短路)	Ign./Distributor Eng.Speed Inp.Circ. No Signal
31	P0480	风扇控制电路开路	cooling fan control Circuit Open
32	P0480	风扇控制电路开路	cooling fan control Circuit Open
33	P0508	怠速执行器控制电路对地短路	Idle Air Control Circuit Low
34	P0509	怠速执行器控制电路对电源短路	Idle Air Control Circuit Low High
35	P0511	怠速执行器控制电路开路	Idle Air Control Circuit Open
36	P0560	系统蓄电池电压信号不合理	System Voltage Malfunction
37	P0562	系统蓄电池电压过低	System Voltage Low Voltage
38	P0563	系统蓄电池电压过高	System Voltage High Voltage

39	P0627	油泵继电器控制电路开路	Fuel Pump “A” Control Circuit /Open
No	Pcode	说明 (UAES)	Decription(UAES)
40	P0628	油泵继电器控制电路对地短路	Fuel Pump “A” Control Circuit Low
41	P0629	油泵继电器控制电路对电源短路	Fuel Pump “A” Control Circuit High
42	P0650	MIL 灯驱动级电路故障	Malfunction Indicator Lamp Control Circ.
43	P0691	风扇控制电路对地短路	cooling fan control Circuit Low
44	P0692	风扇控制电路对电源短路	cooling fan control Circuit High
45	P1116	发动机温度超限	Engine Coolant Temp High

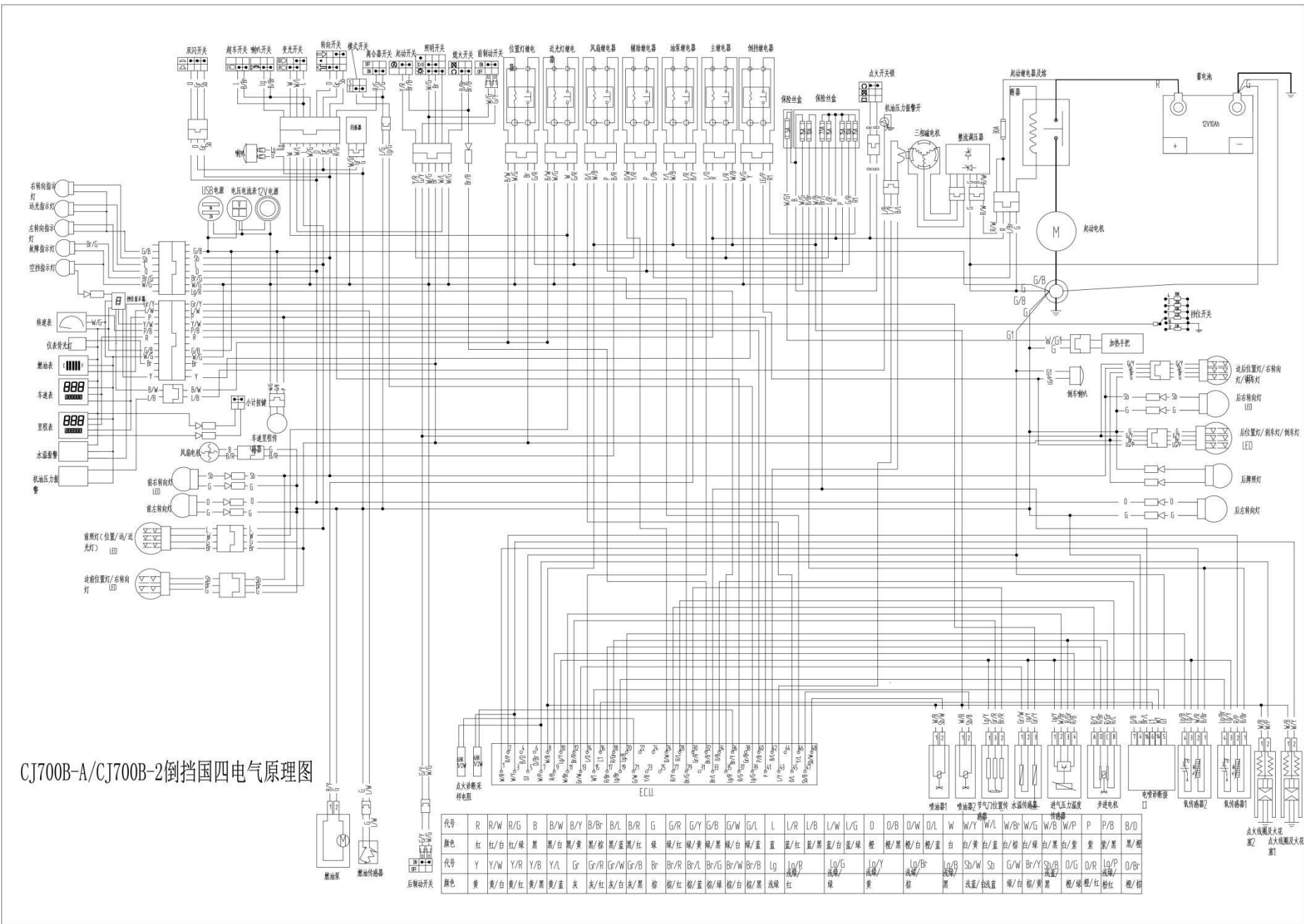

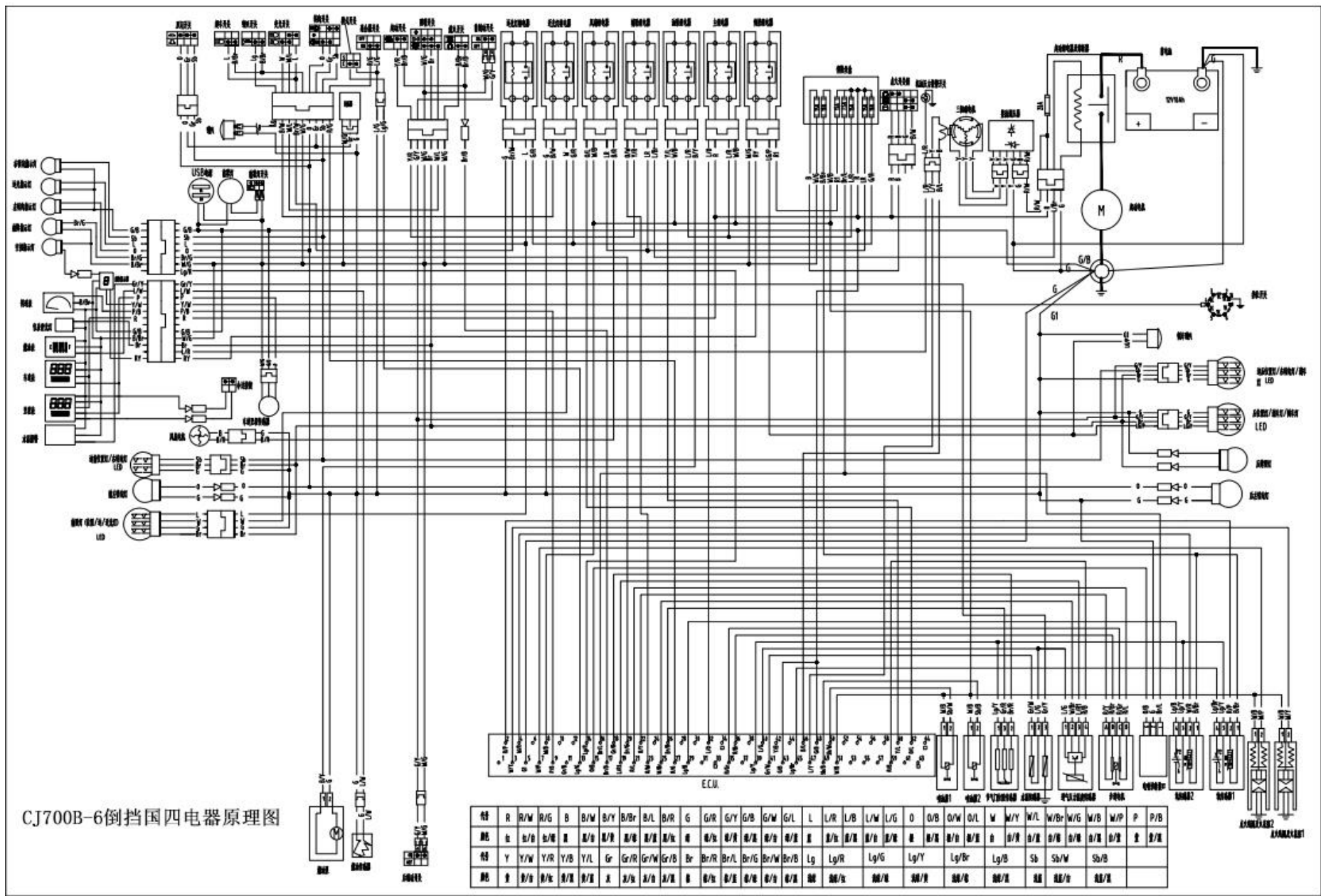

CJ700B-6倒挡国四电器原理图

Common faults and causes of motorcycle

Condition	Component position	Fault cause	Disposal method
Unable to start	Fuel system	There is no fuel in the tank	Add fuel
		The oil pump is blocked or damaged. The fuel quality is poor	Clean or replace
	Ignition system	Fault of sparking plug: too many deposited carbon and long service time	Check or replace
		Fault of sparking plug cap: poor contact or burning	Check or replace
		Ignition coil fault: poor contact or burning	Check or replace
		ECU fault: poor contact or burning	Check or replace
		Coil fault triggering: poor contact or burning	Check or replace
		Stator fault: poor contact or burning	Check or replace
		Faults of all connecting wires: poor contact	Check or adjust
			Check or replace
		Check or replace	

Unable to start			Check or replace
			Check or replace
			Check or replace
Insufficient power	Air valve piston	Excessive carbon deposited in intake, exhaust valve and piston: poor fuel quality and poor oil quality	Repair or replace
	Clutch	Clutch slipping: poor oil quality, long service time and overload	Adjust or replace
	Cylinder body and piston ring	Wearing of cylinder body and piston ring: poor oil quality and long service time	Replace oil
	Brake	In complete brake separation: too tight brake	Adjust
	Big chain	Too tight drive chain: improper adjustment	Adjust
	Engine	Engine overheating: over-rich mixture or over-thin mixture, the poor quality of oil and fuel, obstructions, etc.	Adjust or replace
	Sparking plug	Improper sparking plug clearance. The normal value: 0.8-0.9 mm	Adjust or replace
	Air intake pipe	Air leakage of air intake pipe: too long service time	Adjust or replace
	Air cylinder head	Air cylinder head or air valve is leaked	Check or replace
Electric system	The fault occurs in the electric system	Check or repair	

	Air filter	The air filter is blocked	Clean or adjust
The headlamp and tail lamp do not lighten	Cable	The poor contact occurs in the circuit	Adjust
	Left and right switches	The poor contact occurs in the switch or the switch is damaged	Adjust or replace
	Headlamp	Inspection of bulb and lamp seat	Adjust or replace
	Voltage regulator	Inspection of voltage regulator; poor contact or burning	Check or replace
	Magneto	Inspection of magneto coil; poor contact or burning	Check or replace
The horn does not sound	Battery	There is no sufficient electric quantity in the battery	Charge or replace
	Left switch	Inspection of the horn button	Adjust or replace
	Cable	The poor contact occurs in the circuit	Adjust or repair
	Horn	The horn is damaged	Adjust or replace

The items listed above are the common faults of the motorcycle. In case your motorcycle breaks down (especially in the electronic fuel injection system, fuel evaporation system and alarm system), please contact the “Dealer” promptly for timely inspection and repair.

Users should remember the following contents: It is forbidden to deal with motorcycle’s faults by themselves. Otherwise, it is easy to cause safety hazards or accidents. In case the users handle the motorcycle’s faults by themselves, the users shall be responsible for the safety accidents.